

Orbit motor

Table of Contents

Description	Page No.
H & S Series	3
Features	3
Model code	3
H Series	4-9
Specifications	4
Performance	5
Dimensions and mount data	9
S Series	10-15
Specifications	10
Performance	11
Dimensions and mount data	15
Instruction	16-17
Valves for H & S Series	18-21
2000 Series	22-34
Features	22
Model code	22
Specifications	23
Performance	24
Dimensions and mount data	28
Instruction	35-37
Valves for 2000 Series	38-41
S Series with Mechanical Brake	42-44
Features	42
Specifications	42
Model code	43
Dimensions and mount data	44
2000 Series with Mechanical Brake (Brake Torque 98-196Nm)	45-47
Features	45
Specifications	45
Model code	45
Dimensions and mount data	46
2000 Series with Mechanical Brake (Brake Torque 294-392Nm)	48-49
Specifications	48
Model code	48
Dimensions and mount data	49
Orbit Motor, Optional Product	50
Direct Mount Valves	51

H & S Series

Features

- Complete with a distinct reducing mechanism of its own based on Gerotor/Geroler, the motors of this series deliver high output torque throughout their speed range.
- No additional speed reducer is needed because of low-speed High-torque performance.
- It is possible to install the motors into the small space because of small and compact size.
- The motors operate smoothly in any installation points.
- The torque which occurs irrespective of the direction of rotation is the same. Also, it is possible to reverse, being immediate.
- The rotation speed can be easily and smoothly controlled by crossing in the wide range.
- Irrespective of the load, the rotation speed can be kept constant.

Model code procedure

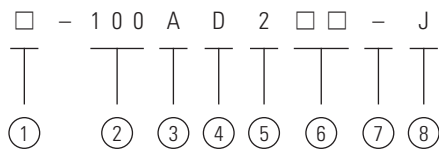

① Series

- H** = H series
- S** = S series

② Displacement

③ Port

- A** = G1/2 O-Ring ports
- B** = Manifold mount
- C** = 1/2NPTF ports
- D** = Rc1/2 ports

④ Shaft

- B** = SAE Splined shaft
- C** = Ø1" Straight with Woodruff key
- D** = Ø25 Straight with Parallel key, 8mm

⑤ Flange mounting

- 2** = 2 Bolt
- 4** = 4 Bolt

⑥ Special features (none of standard motor)

- B** = Special seal for Phosphate Ester Fluid
- D** = Integral check valves (H series only)
- F** = Free running (H series only)
- M** = Metric mounting holes

⑦ Drain port

- = Without drain port (H series only)
- x = With drain port (H series; option, S series; standard)

⑧ Design code

- H Series J** = Model 9
- S Series M** = Model 12

H Series

Specifications

Model	Displacement	Continuous Speed	Intermittent Speed	Continuous Torque	Intermittent Torque	Continuous Pressure	Intermittent Pressure	Peak Back Pressure	Weight
	cm ³ /rev	rpm	rpm	N-m (kgf-m)	N-m (kgf-m)	MPa (kgf/cm ²)	MPa (kgf/cm ²)	MPa (kgf/cm ²)	Kg
H-040	40	930	1000	59 (6.0)	83 (8.5)	12.3 (125)	16.7 (170)	10.2 (105)	5.4
H-050	51	910	980	79 (8.0)	108 (11.0)	12.3 (125)	16.7 (170)	10.2 (105)	5.4
H-070	69	770	880	108 (11.0)	147 (15.0)	12.3 (125)	16.7 (170)	10.2 (105)	5.5
H-100	96	560	670	147 (15.0)	206 (21.0)	12.3 (125)	16.7 (170)	10.2 (105)	5.6
H-130	129	420	560	206 (21.0)	265 (27.0)	12.3 (125)	16.7 (170)	10.2 (105)	5.7
H-170	159	340	450	226 (23.0)	304 (31.0)	11.3 (115)	15.2 (155)	10.2 (105)	5.9
H-200	184	290	390	255 (26.0)	343 (35.0)	10.8 (110)	14.7 (150)	10.2 (105)	6.1
H-240	230	240	320	285 (29.0)	402 (41.0)	9.8 (100)	13.7 (140)	10.2 (105)	6.3
H-290	277	200	260	334 (34.0)	412 (42.0)	9.3 (95)	11.7 (120)	10.2 (105)	6.4
H-390	369	150	200	392 (40.0)	461 (47.0)	8.3 (85)	9.8 (100)	10.2 (105)	7.0

Note: 1. Intermittent Torque, Pressure and Speed : Intermittent operation, 10% of every minute. A simultaneous Intermittent Torque and Intermittent Speed condition must not occur.

2. Maximum pressure at the motor inlet port of 17.2MPa (175kgf/cm²)

3. Splined shafts are recommended whenever operating above 350Nm of torque.

Sectional view

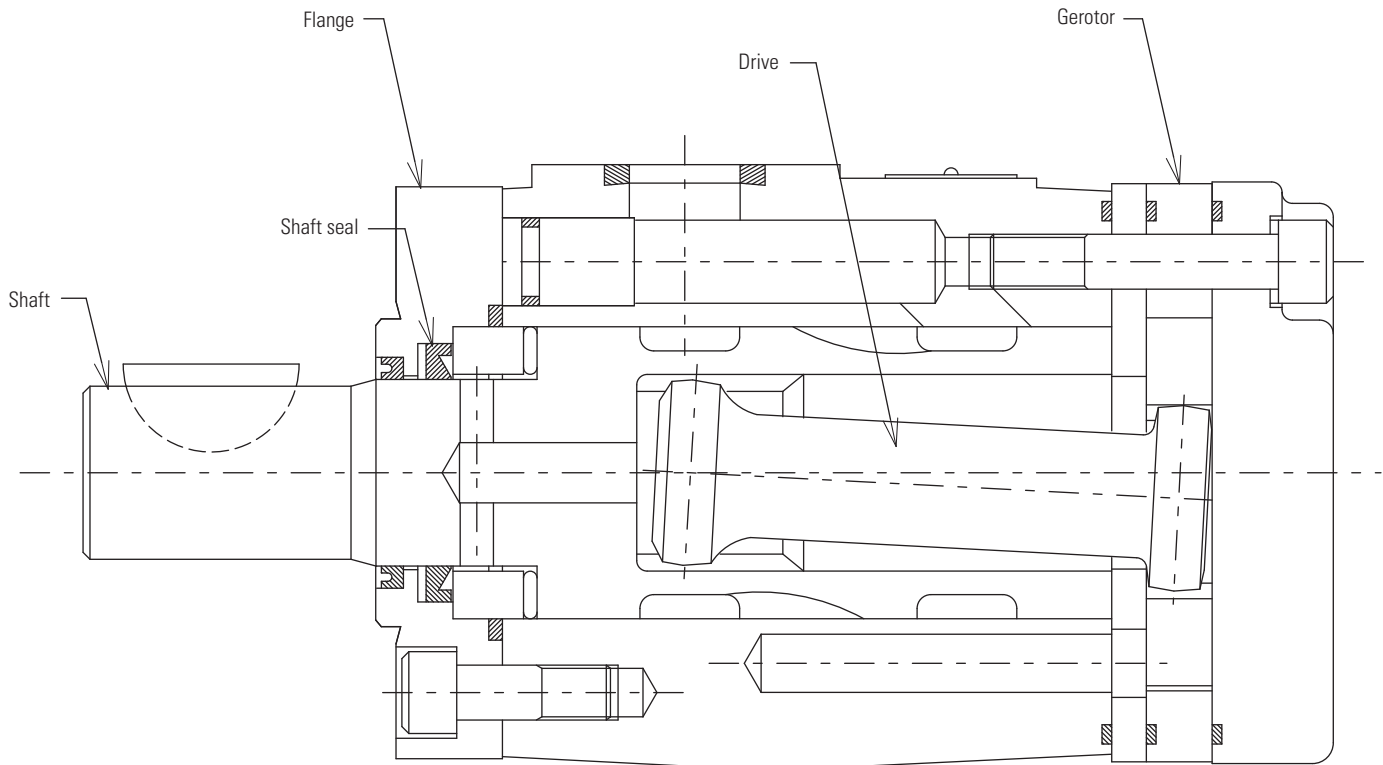

H Series

Performance data

The performance data on this catalogue show the typical Torque Efficiency and Volume Efficiency of H series motors at each pressure at 37 cSt.

N_{th} = Theoretical Speed (rpm)

q = Displacement (cm^3/rev)

η_v = Volumetric Efficiency

N = Speed (rpm)

ΔP = Pressure Difference between inlet port and outlet port (MPa)

T_{th} = Theoretical Torque (N-m)

Q = Inlet Flow (l/min)

η_T = Torque Efficiency

T = Actual Torque (N-m)

$N_{th} = Q \times 10^3 / q$ $N = N_{th} \times \eta_v$

$T_{th} = \Delta P \times q / 2\pi$ $T = T_{th} \times \eta_T$

Note: These data are not guaranteed data.

H - 040 ($40cm^3/rev$)

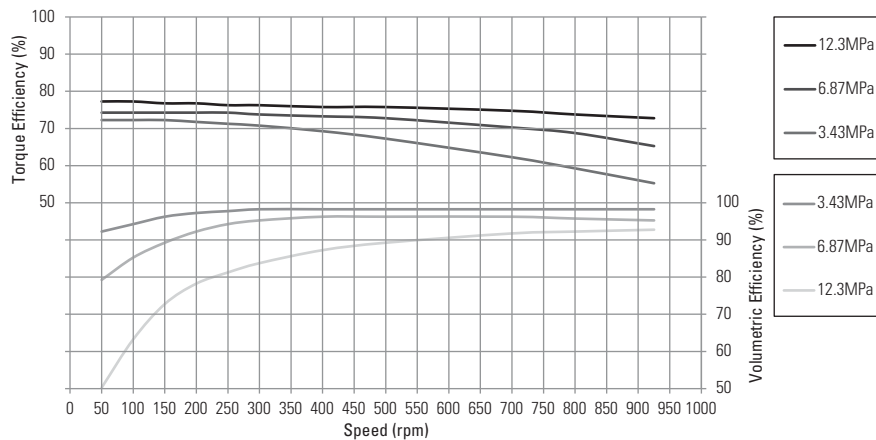

H - 050 ($51cm^3/rev$)

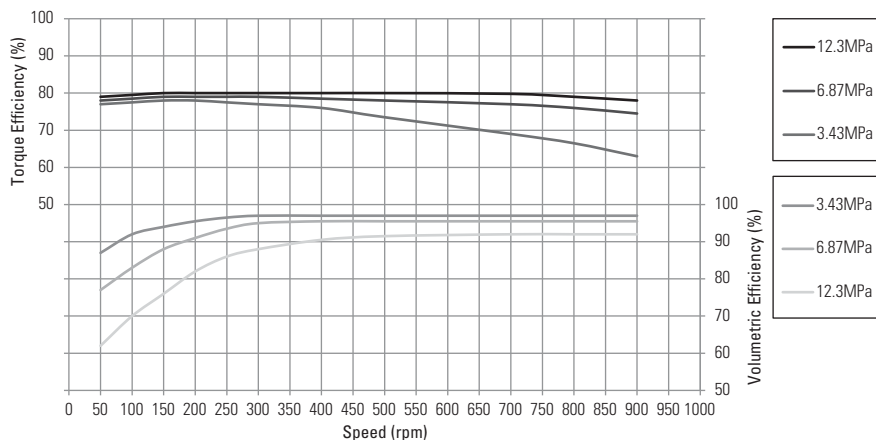

H Series

H - 070 (69cm³/rev)

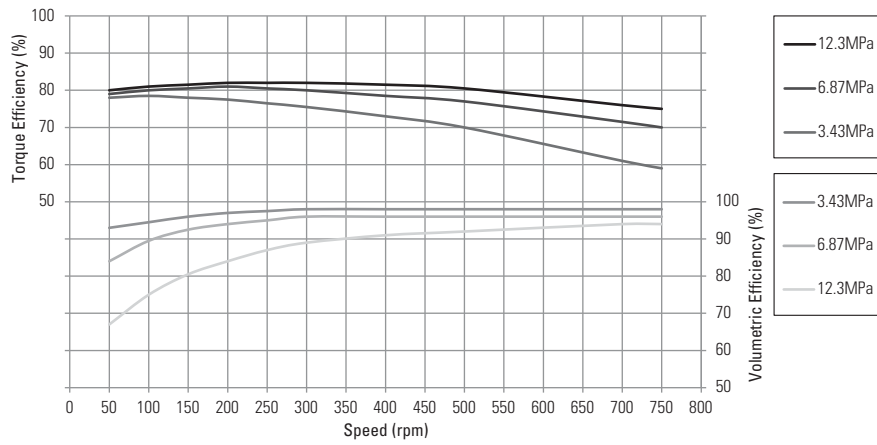

H - 100 (96cm³/rev)

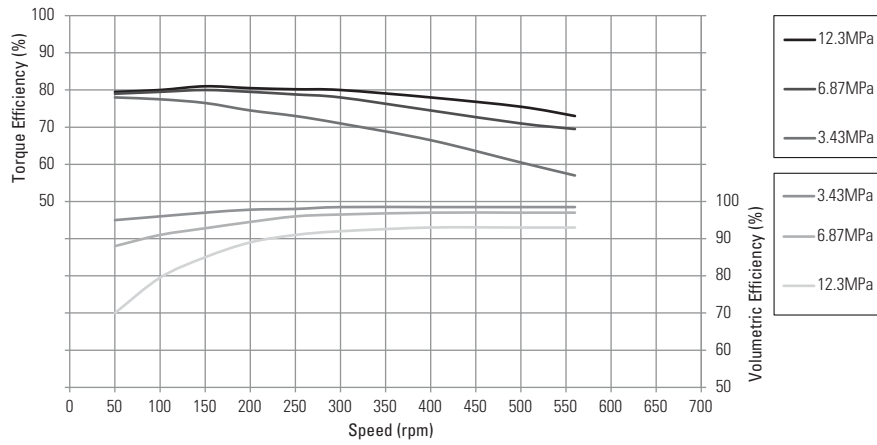

H - 130 (129cm³/rev)

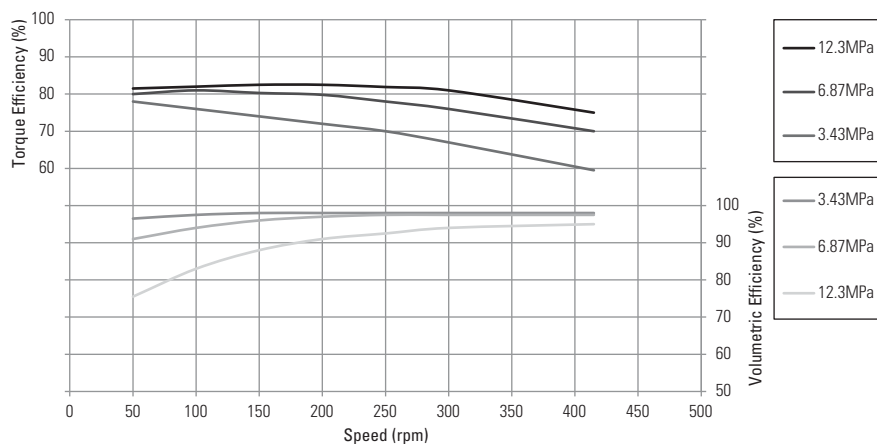

H Series

H - 170 (159cm³/rev)

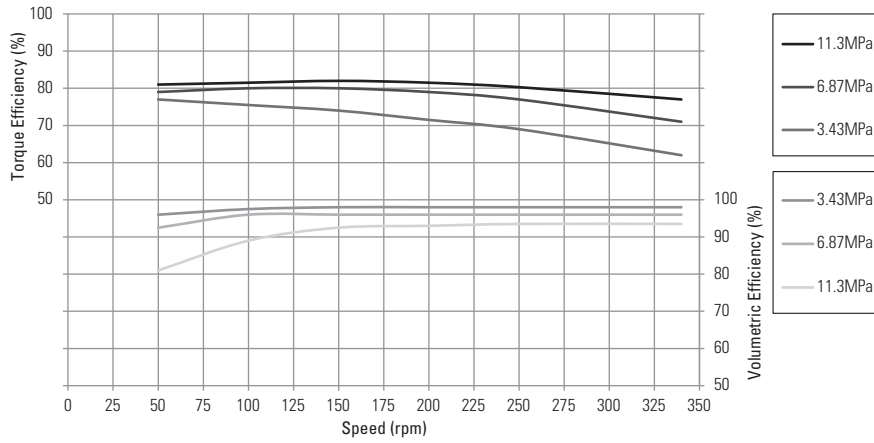

H - 200 (184cm³/rev)

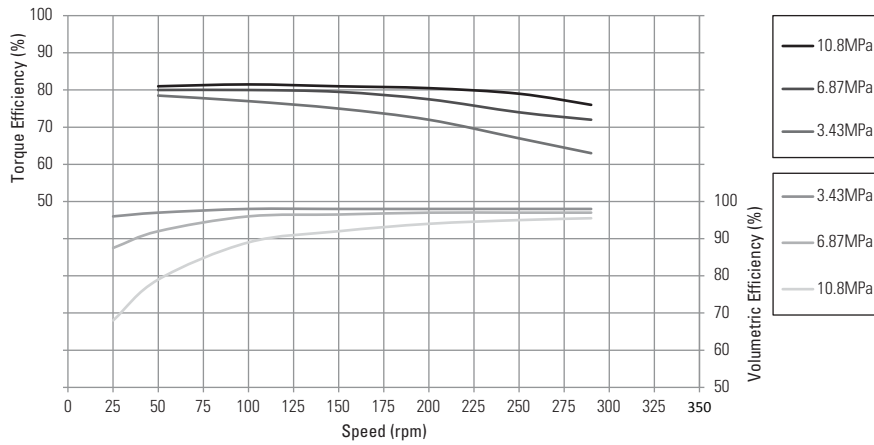

H - 240 (230cm³/rev)

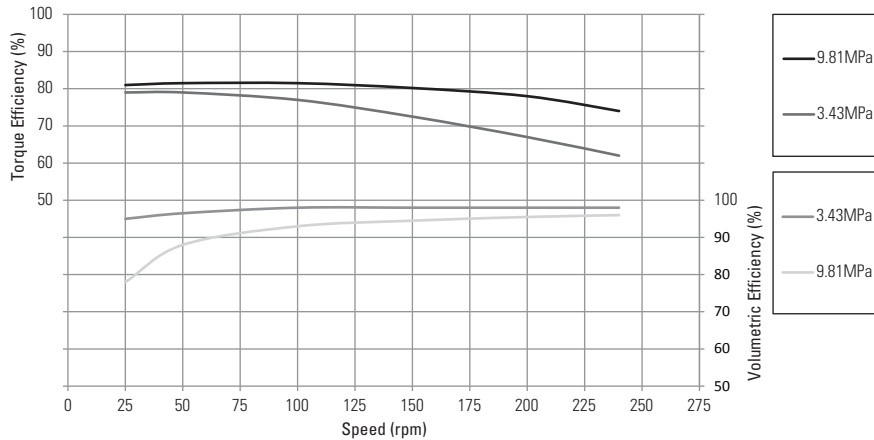

H Series

H - 290 (277cm³/rev)

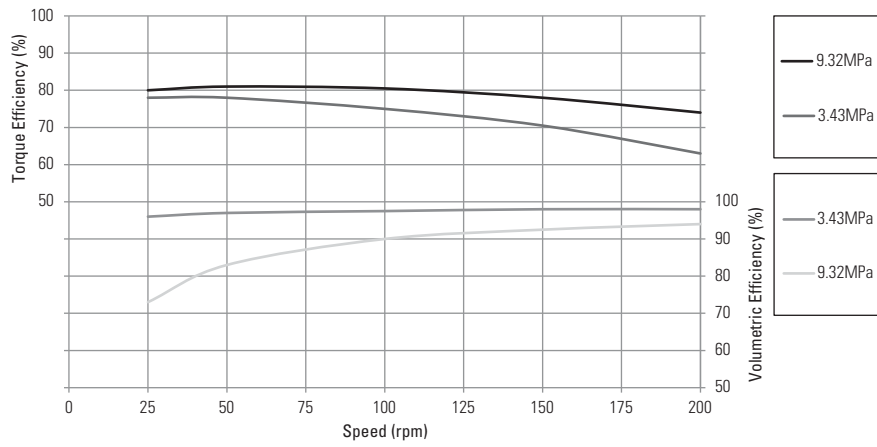

H - 390 (369cm³/rev)

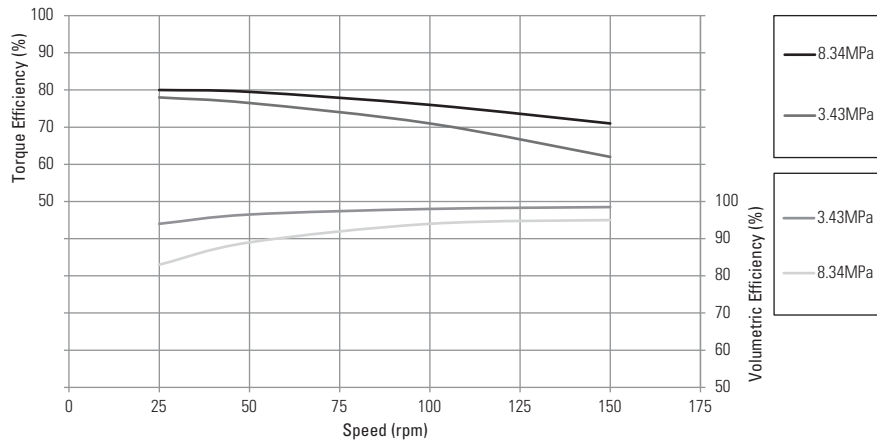

S Series

Specifications

Model	Displacement cm ³ /rev	Continuous Speed rpm	Continuous Inlet Flow L/min	Intermittent Inlet Flow L/min	Continuous Torque N-m (kgf-m)	Intermittent Torque N-m (kgf-m)	Continuous Pressure MPa (kgf/cm ²)	Intermittent Pressure MPa (kgf/cm ²)	Peak Back Pressure MPa (kgf/cm ²)	Weight Kg
S-050	58	963	57	68	106 (10.8)	133 (13.6)	13.8 (140)	17.2 (175)	10.3(105)	6.6
S-070	76	742	57	76	139 (14.2)	175 (17.9)	13.8 (140)	17.2 (175)	10.3(105)	6.7
S-100	93	607	57	76	174 (17.7)	216 (22.0)	13.8 (140)	17.2 (175)	10.3(105)	7.0
S-120	120	472	57	76	224 (22.8)	279 (28.5)	13.8 (140)	17.2 (175)	10.3(105)	7.2
S-140	144	394	57	76	258 (26.3)	319 (32.5)	13.1 (133)	16.2 (165)	10.3(105)	7.3
S-160	165	343	57	76	296 (30.2)	359 (36.6)	13.1 (133)	15.9 (162)	10.3(105)	7.4
S-190	186	304	57	76	326 (33.3)	395 (40.3)	12.8 (130)	15.5 (158)	10.3(105)	7.6
S-220	224	253	57	76	359 (36.6)	435 (44.4)	11.7 (120)	14.1 (144)	10.3(105)	7.9
S-300	299	190	57	76	422 (43.0)	507 (51.7)	10.3 (105)	12.4 (126)	10.3(105)	8.4
S-380	371	153	57	76	457 (46.6)	523 (53.3)	9.0 (92)	10.3 (105)	10.3(105)	8.8

Note: 1. Intermittent Torque, Pressure, Flow and Speed : Intermittent operation, 10% of every minute. A simultaneous Intermittent Torque and Intermittent Speed and Flow condition must not occur.

2. Maximum pressure at the motor inlet port of 17.2MPa (175kgf/cm²)

3. Splined shafts are recommended whenever operating above 350N-m of torque.

Sectional view

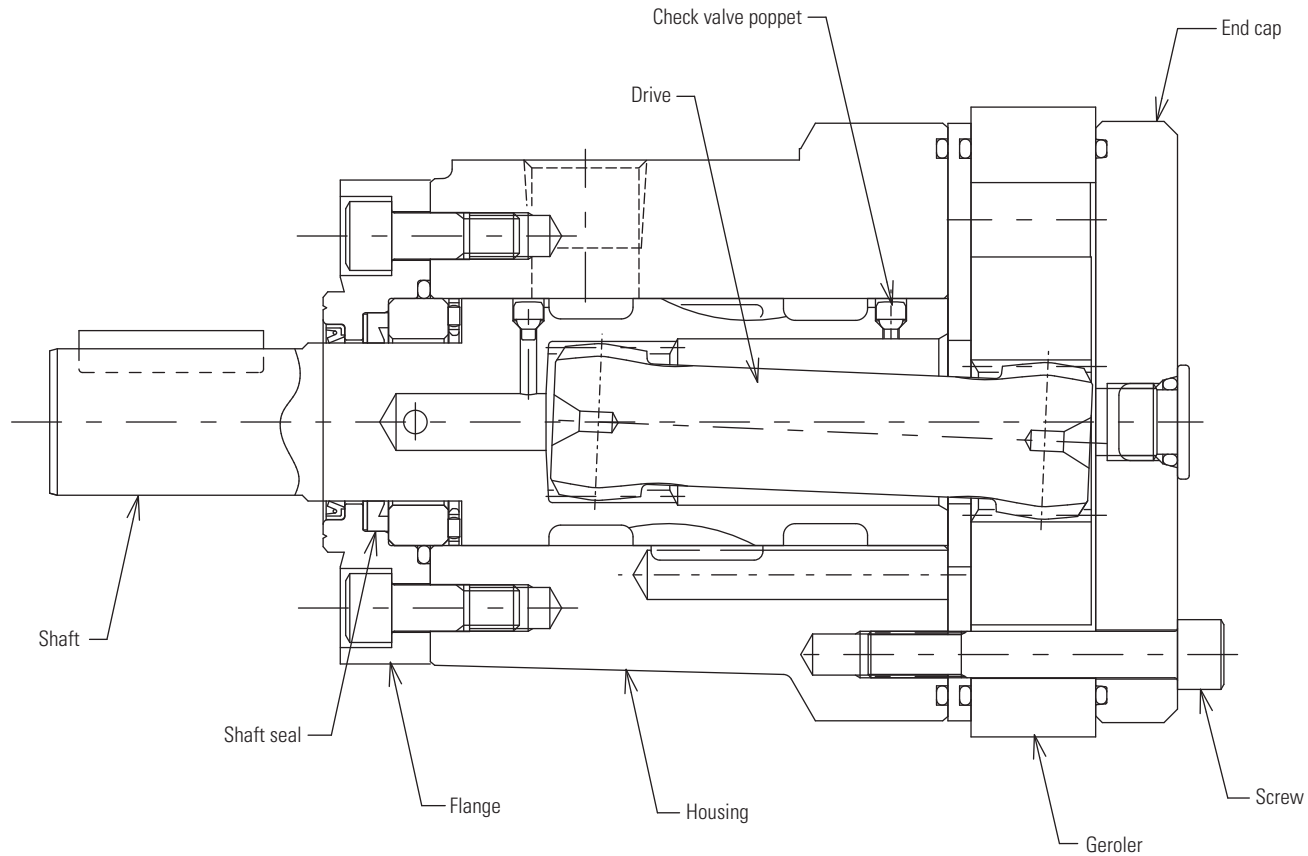

S Series

Performance data

The performance data on this catalogue show the typical Torque Efficiency and Volume Efficiency of S series motors at each pressure at 37 cSt.

N_{th} = Theoretical Speed (rpm)

q = Displacement (cm^3/rev)

η_v = Volumetric Efficiency

N = Speed (rpm)

ΔP = Pressure Difference between inlet port and outlet port (MPa)

T_{th} = Theoretical Torque (N-m)

Q = Inlet Flow (l/min)

η_T = Torque Efficiency

T = Actual Torque (N-m)

$N_{th} = Q \times 10^3 / q$ $N = N_{th} \times \eta_v$

$T_{th} = \Delta P \times q / 2\pi$ $T = T_{th} \times \eta_T$

Note: These data are not guaranteed data.

S - 050 ($58cm^3/rev$)

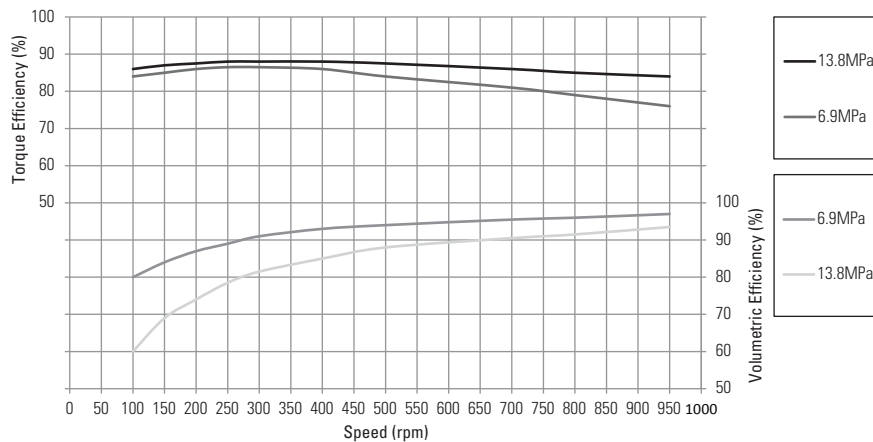

S - 070 ($76cm^3/rev$)

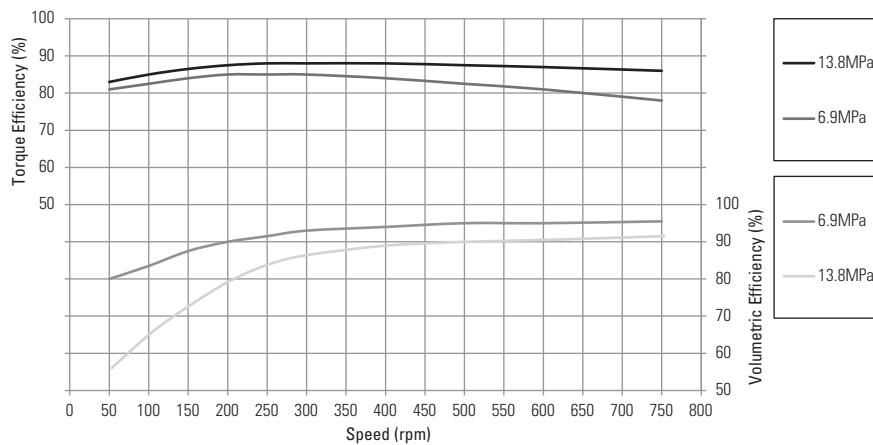

S Series

S - 100 (93cm³/rev)

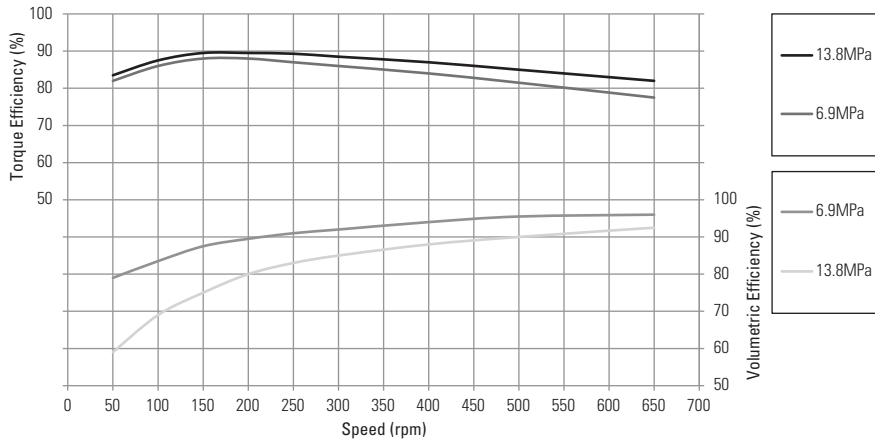

S - 120 (120cm³/rev)

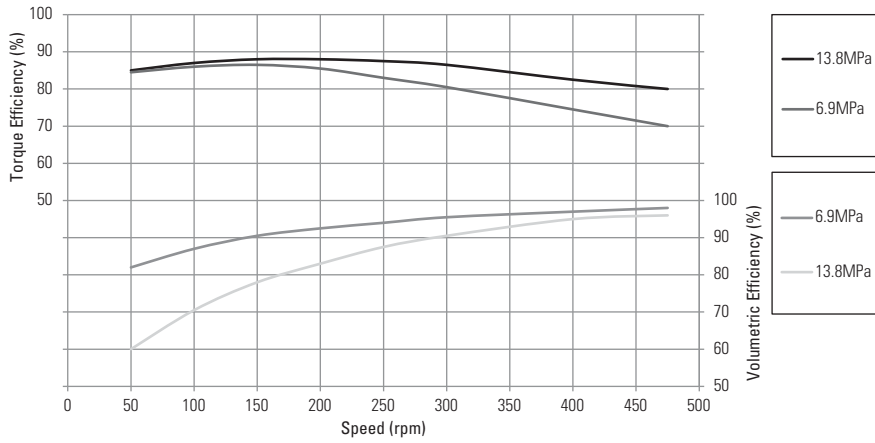

S - 140 (144cm³/rev)

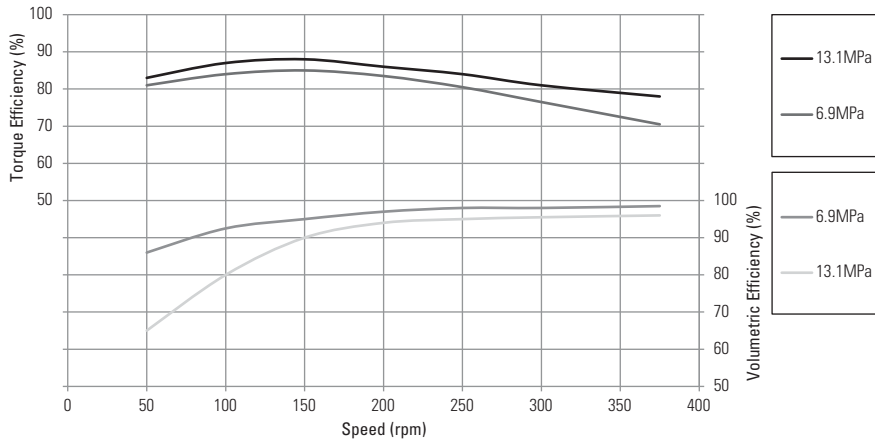

S Series

S - 160 (165cm³/rev)

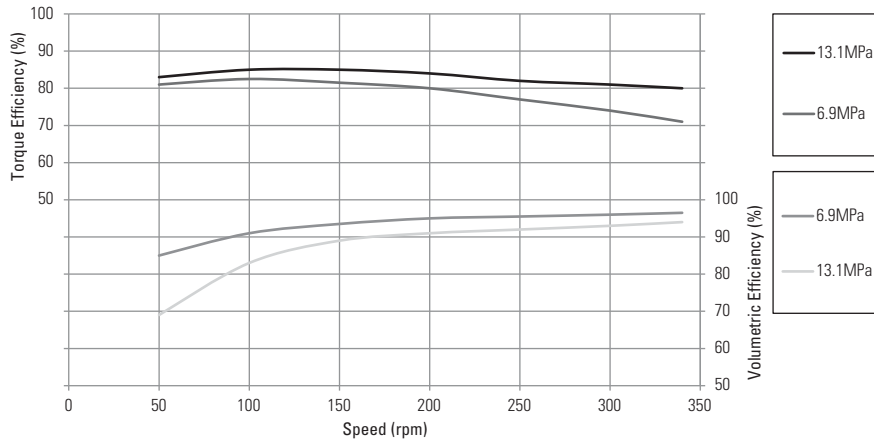

S - 190 (186cm³/rev)

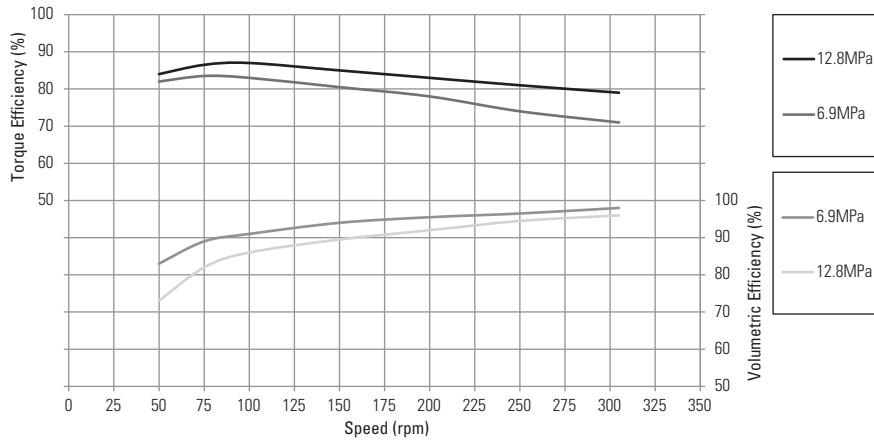

S - 220 (224cm³/rev)

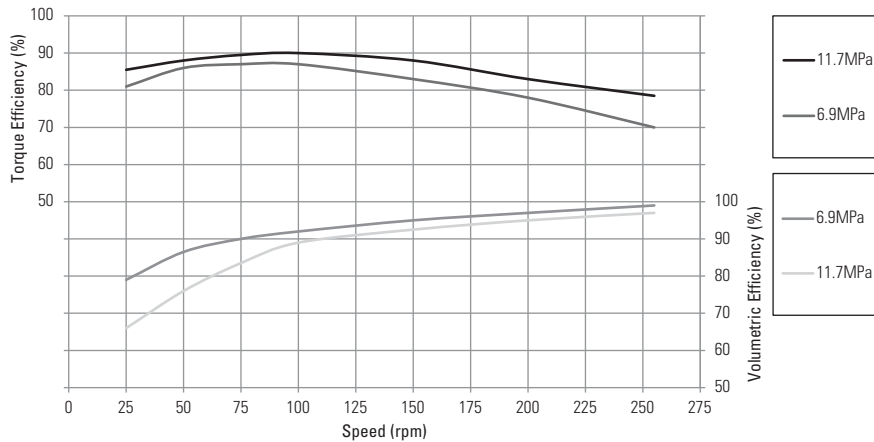

S Series

S - 300 (299cm³/rev)

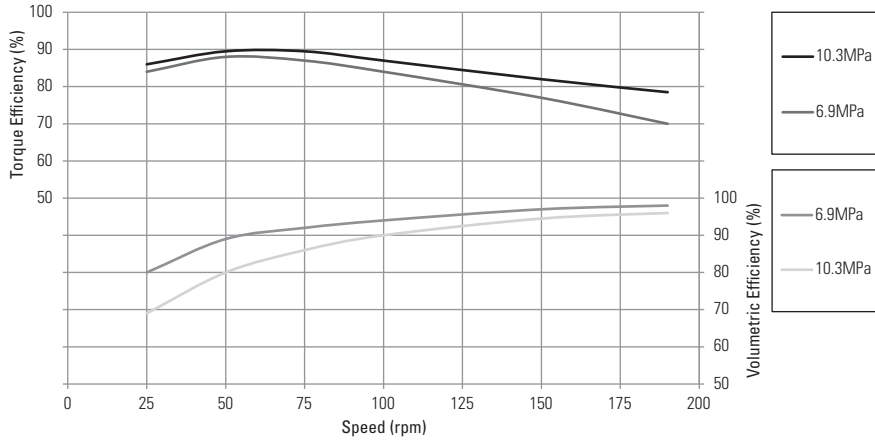

S - 380 (371cm³/rev)

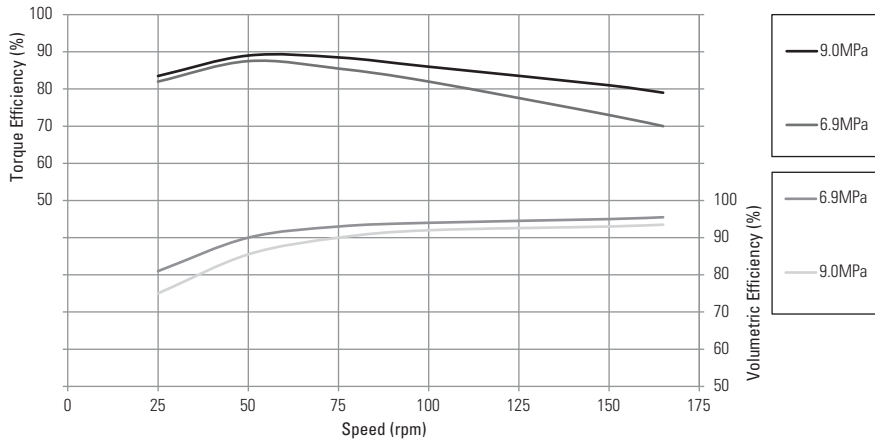

S Series

Dimensions and mount data

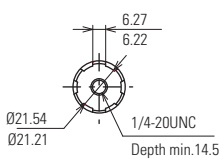
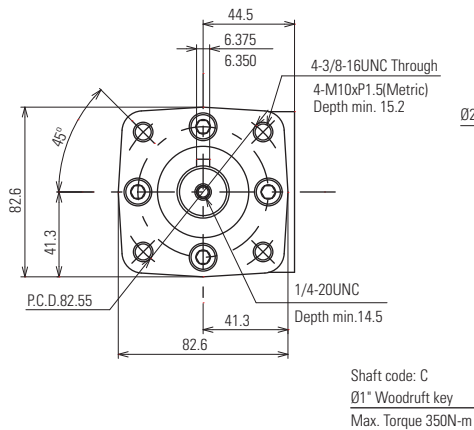
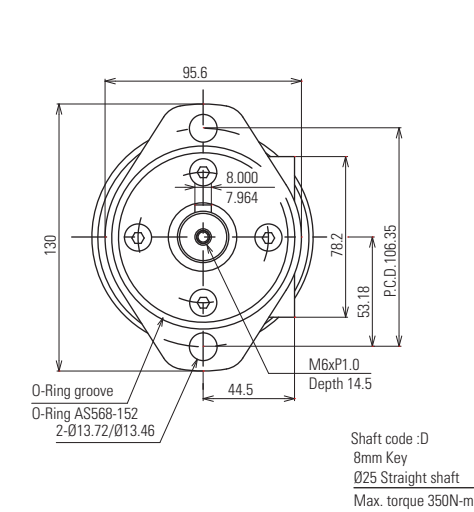

Shaft code: B
SAE 6B Splined shaft

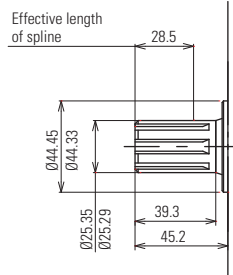
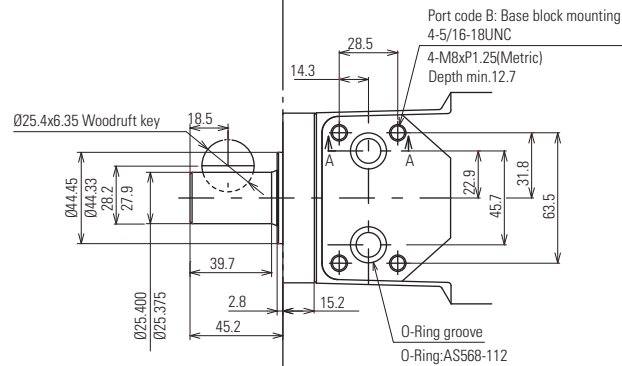
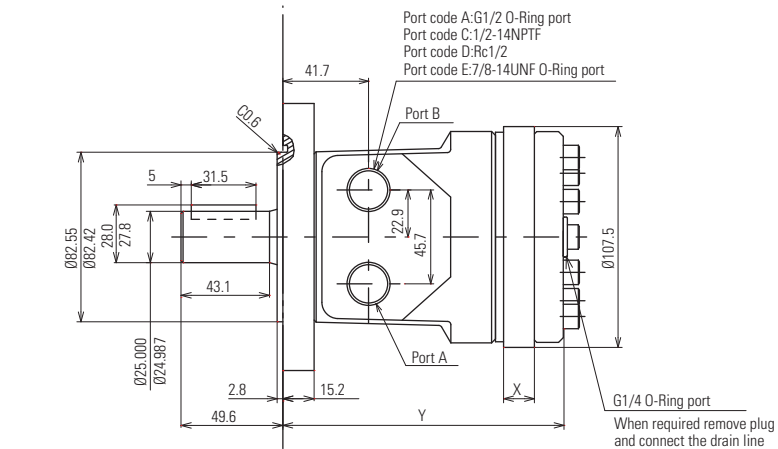
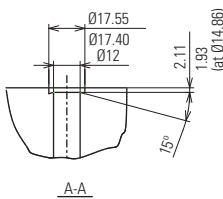

Rotation: Viewed from shaft end

- CW: Port A pressurized
- CCW: Port B pressurized

Model	X: Gerotor Width	Y: Length
S-050	7.5	136.8
S-070	9.8	139.1
S-100	12.0	141.3
S-120	15.5	144.7
S-140	18.6	147.8
S-160	21.3	150.5
S-190	24.0	153.2
S-220	28.9	158.1
S-300	38.5	167.8
S-380	47.9	177.1

Recommended tightening torque for motor mounting

Port Size	Tightening Torque
G1/2	59 N-m(6kgf-m)
Rc1/2	59 N-m(6kgf-m)
1/2-14NPTF	59 N-m(6kgf-m)
G3/8	39 N-m(4kgf-m)
G1/4	24.5 N-m(2.5kgf-m)

Instruction

Instruction for use

Permissible back pressure and case pressure

- In case of series connection or closed circuit (HST circuit), a case drain is necessary.
- The permissible case pressure in the chart shows the permissible case pressure at each motor shaft speed.
 - S Series Motor has internal check valve, and the back pressure (return pressure) is permissible to the pressure in the chart.
 $P_c = P_2 \dots \dots \dots (1)$
 - H Series Motor doesn't have internal check valve. The case pressure operates to shaft seal. Use for the case pressure which is calculated by the following formula to become under than the chart pressure.
 $P_c = \text{Case Pressure (MPa)}$
 $P_c = 0.6\Delta P + P_2 \dots \dots \dots (2)$
 $\Delta P = P_1 - P_2$: Pressure Difference between inlet port and outlet port (MPa)
 P1: Inlet Port Pressure (MPa)
 P2: Outlet Port Pressure (Back Pressure) (MPa)
- In case of the pressure which was calculated in (1) or (2) exceeds the permission case pressure of the chart, the case drain is necessary.

Note:

- The standard type H motor doesn't have a drain port. In case of needing a case drain, select a H motor with the drain port from the model numbering procedure.
- H Series Motor has the special specification which has a check valve. Special features symbol is "D"

Side load capacity

- These charts are based on the load being applied at the location shown. Side load capacity decreases when load is applied at distances greater than shown.
- This side load chart shows relation between the shaft speed and the permission side load when the load acts on the 27 mm position from the flange mounting surface. The side load when the load position is different is calculated by the following formula.

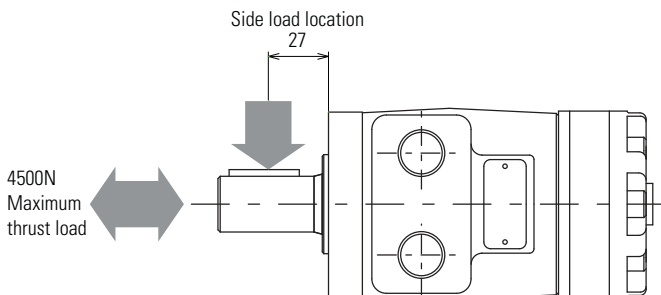

Permissible Case Pressure

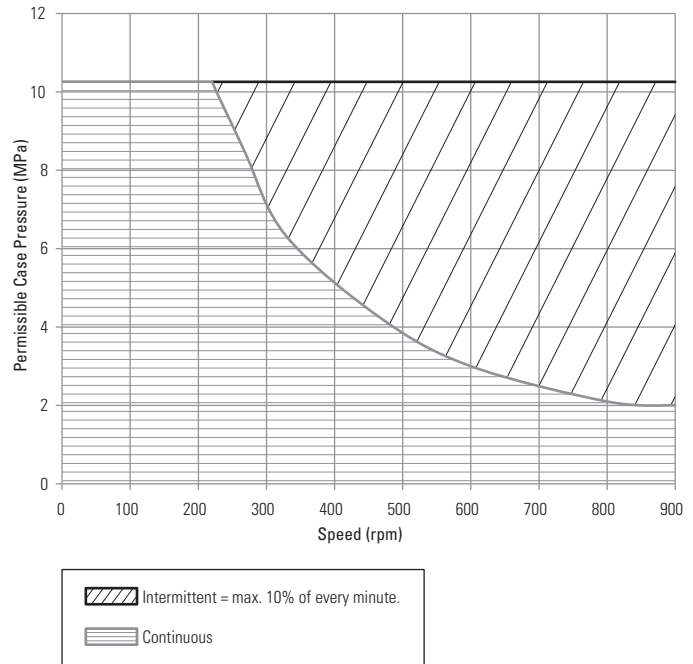

Allowable Side Load

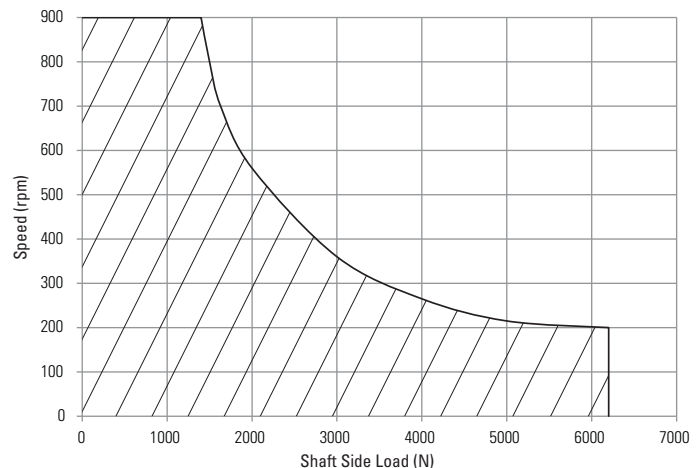

Instruction

Fr : Side load from the chart (N)

Fro: Permission side load at the load point

X : The distance from rated side load point (27mm from flange mounting surface).

The side of the end of the shaft is "+" and the side of the flange is "-".

$$Fro = 130Fr / (130+x)$$

External thrust load can be applied by maximum 4500N either direction simultaneously.

<Calculation Example>

① Motor Shaft Speed 350rpm, Distance from flange mounting surface 40mm

From the chart Fr = 3000N X = +13mm

$$Fro = 130Fr / (130+X) = 130/143 \times 3000 = 2700N$$

② Motor Shaft Speed 350rpm, Distance from flange mounting surface 17mm

From the chart Fr = 3000N X = -10mm

$$Fro = 130Fr / (130+X) = 130/120 \times 3000 = 3250N$$

Hydraulic fluid

Recommended Fluid; Mineral based Anti-Wear Hydraulic Fluid ISO VG32, VG46, VG56, VG68, or equivalent fluid

Allowable Fluid Temperature Range; from -30 to +80 degrees C.

Recommended Viscosity Range; from 24 to 50 cSt

The allowable lowest viscosity; 13 cSt (for H series ; 20 cSt)

The allowable highest viscosity; 2158 cSt

Recommended Filtration; 10 micron or finer

Fluid Cleanness; ISO 18/13 or finer

Note: If the motor is used with special fluid such as flame-resistant fluid, please contact Eaton because special seals etc. are needed.

Inertia load application, etc.

When the motor is used in the inertia load application such as swing drive, it is necessary to use the brake valve in order to protect the motor and its shaft.

When the motor acts as a pump in the winch drive application or down-slope travel application, it is often necessary to use the counter balance valve in order to prevent the circuit cavitation or reckless driving by the self-weight.

In these cases, please contact Eaton for details.

Valves for H and S Series

VSE Brake valve for direct connection

<Features> Total system will be designed economically because this can be connected directly with H/S series motor. This valve prevents an irregular high pressure by inertia load at accelerating, decelerating and stopping and then safe operation is ensured.

<Specifications> Rated Flow: 15l/min
 Pressure Range: 6.9~13.7MPa (70~140kgf/cm²)
 Weight: 1.9kg

VSE Pressure Override Performance

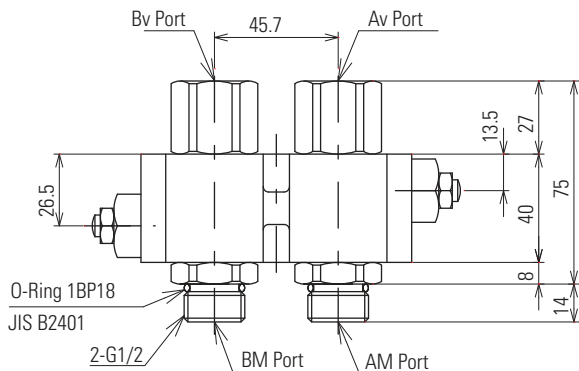
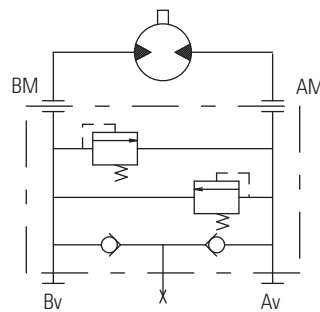
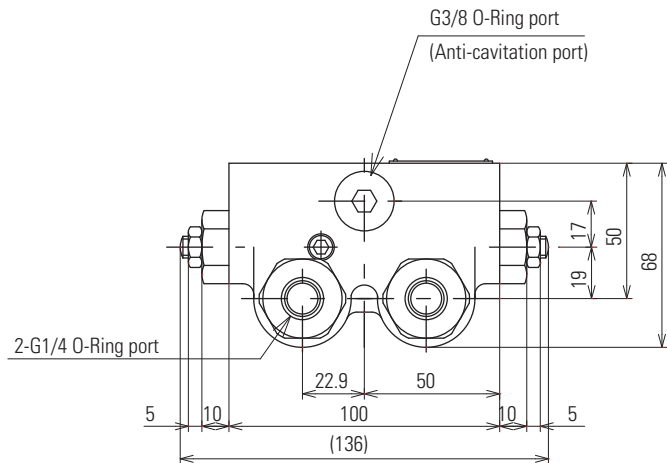
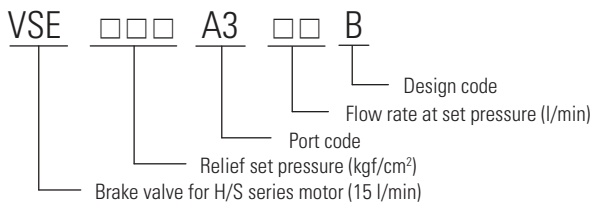
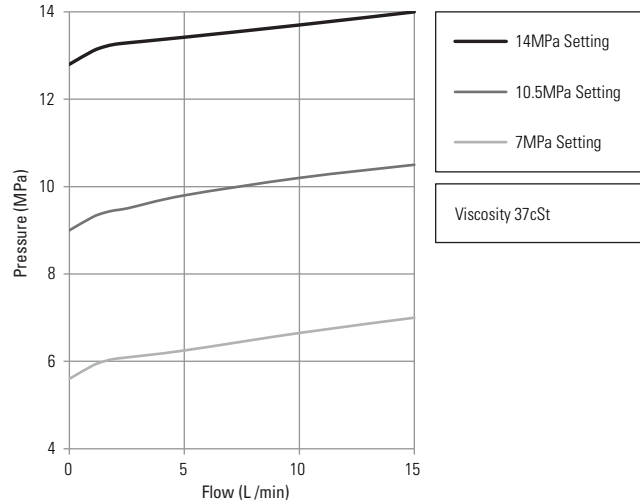

Valves for H and S Series

VSC Counter balance valve for direct connection

<Features> Total system will be designed economically because this can be connected directly with H/S series motor. This can be connected directly with direct connected brake valve. The circuit cavitation or reckless driving by the self-weight can be prevented.

<Specifications> Max. Pressure: 17.2MPa (175kgf/cm²)
 Rated Flow: 30l/min
 Spool Cracking Pressure: 0.3MPa (3.5kgf/cm²)
 Weight: 2.0kg

VSC Pressure Drop Performance

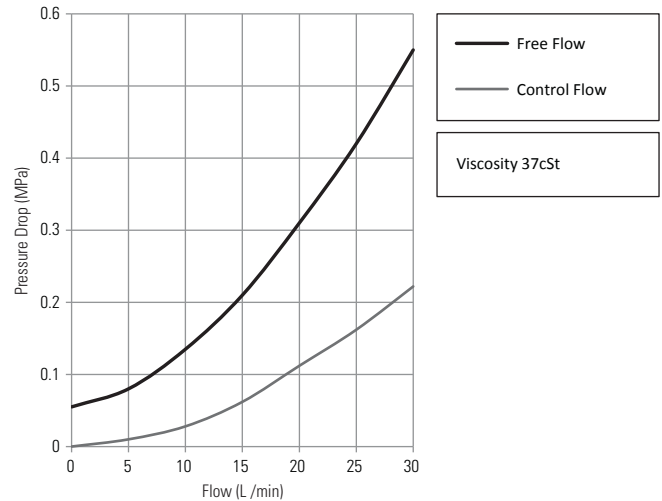

VSC A7 A

Design code
 Port code
 Counter balance valve for H/S series motor (30 l/min)

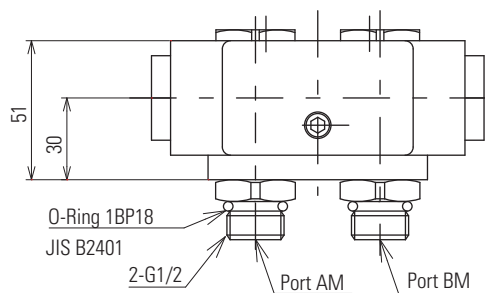
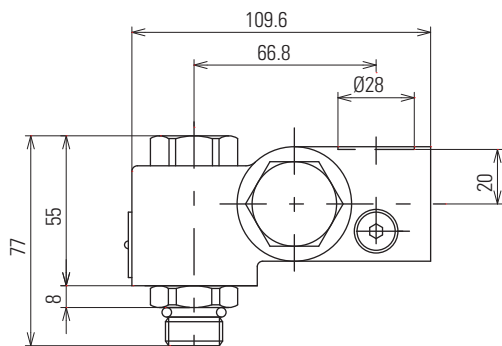
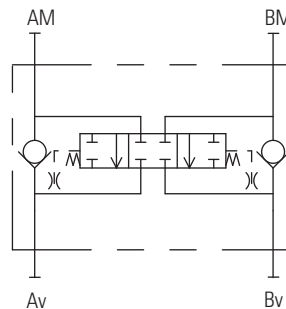
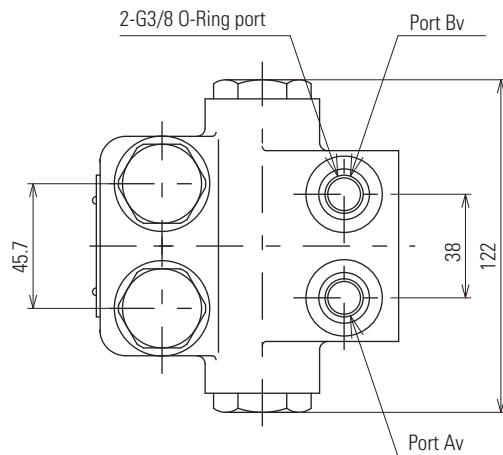

Valves for H and S Series

VSA Counter balance valve for direct connection

<Features> Total system will be designed economically because this can be connected directly with H/S series motor. The circuit cavitation or reckless driving by the self-weight can be prevented.

<Specifications> Max. Pressure: 17.2MPa (175kgf/cm²)

Rated Flow: 30l/min

Spool Cracking Pressure: 0.3MPa (3.5kgf/cm²)

Weight: 2.0kg

VSA Pressure Drop Performance

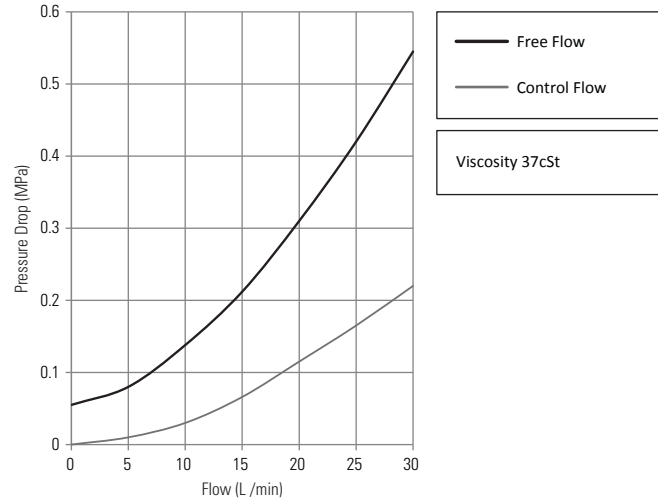

VSA A1 A

Design code
Port code
Counter balance valve for H/S series motor (30 l/min)

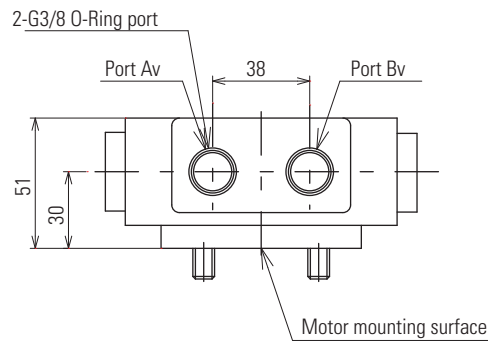
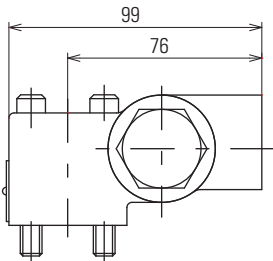
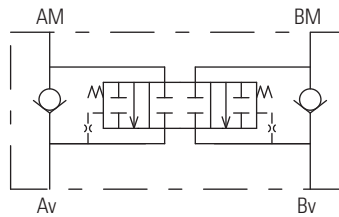
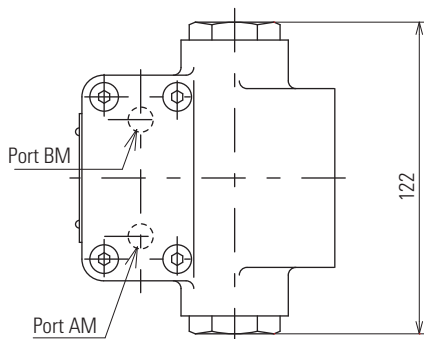

Valves for H and S Series

VSW Integrated brake valve and counter balance valve for direct connection

<Features> Total system will be designed economically because this can be connected directly with H/S series motor. This valve prevents an irregular high pressure by inertia load at accelerating, decelerating and stopping and then safe operation is ensured. The reckless driving by the self-weight can be prevented.

<Specifications> Max. Pressure: 17.2MPa (175kgf/cm²)
 Max. Flow: 60l/min
 Spool Cracking Pressure: 0.3MPa (3.5kgf/cm²)
 Pressure Range: 6.9~17.2MPa (70~175kgf/cm²)
 Weight: 3.8kg

VSW Pressure Drop Performance

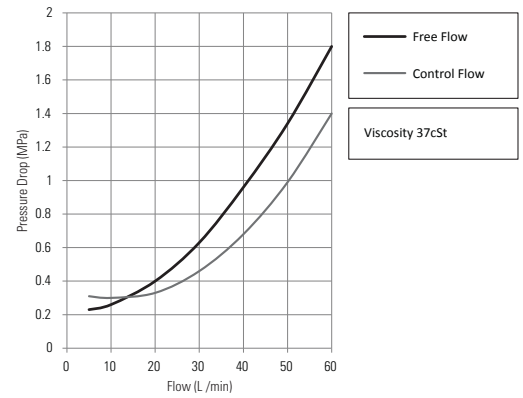

VSW Pressure Override Performance

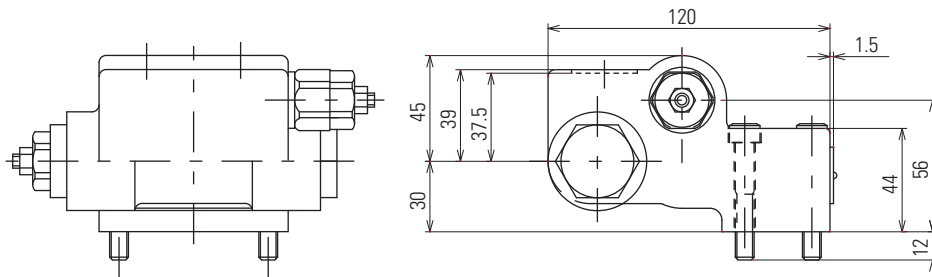
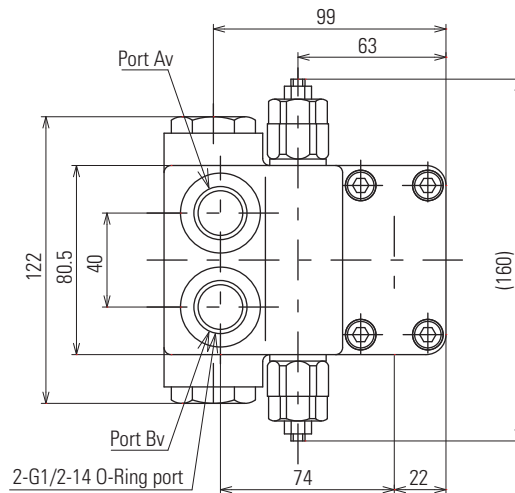
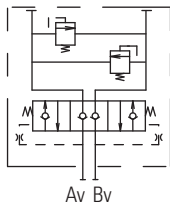
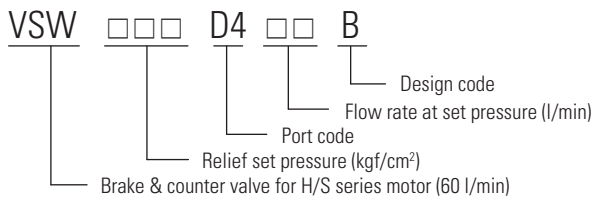
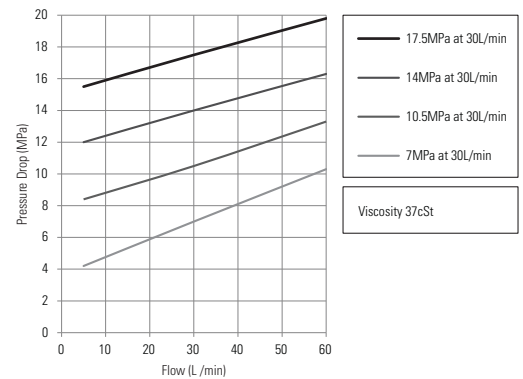

2000 Series

Features

- **The light-weight and compact low-speed high torque motor**

Because Geroler does a planetary motion, the torque which is the same as the case to have decelerated the hydraulic motor of other types in 1/6 with the mechanical reduction gear is gotten. Because nine types displacement of 78-393cm³/rev, even if it doesn't use a reduction gear, the motor which was fitted to the purpose can be selected.

- **The high pressure rating**

There are few internal oil leakage and they can be operated in rated pressure 20.6MPa

(210kgf/cm²), maximum pressure 30.9MPa (315kgf/cm²), because it use of hydraulic pressure balanced type disk valve for the valve-mechanism and it is using high-precision geroler.

- **The accurate valve timing**

Because the disc valve is built independent structurally from the drive transmitting mechanism-device into motor, ensures the accurate valve timing and the high performance that stays stable for long operation hours.

Model code procedure

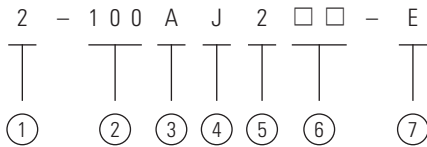

① **Series**

2 = 2000 series

② **Displacement**

③ **Type of motor**

A = Standard
B = Wheel

④ **Shaft**

J = Ø32 Straight with 10x8x31.5 key
B = Ø1-1/4" Splined
C = Ø1-1/4" Tapered
D = Ø1-1/4" Straight with 5/16" Square key
E = Ø1" Straight with Woodruff key

⑤ **Flange mounting**

2 = 2 Bolt
4 = 4 Bolt
6 = 4 Bolt (unequally spaced)

⑥ **Special features (none of standard motor)**

None = G1/2 O-Ring ports
A = 7/8UNF Side ports
B = Special seal for Phosphate Ester Fluid
C = Rc1/2 Side ports
D = 7/8UNF Rear ports
B8 = G1/2 Rear ports
U = 7/8UNF Side ports (Pitch 50.8mm)
Y = Manifold ports (Pitch 50.8mm)

⑦ **Design code**

E = Model 5

2000 Series

Specifications

Model	Displacement	Continuous Speed	Intermittent Speed	Continuous Torque	Maximum Torque	Continuous Pressure	Maximum Pressure	Peak Back Pressure	Weight
	cm ³ /rev	rpm	rpm	N-m (kgf-m)	N-m (kgf-m)	MPa (kgf/cm ²)	MPa (kgf/cm ²)	MPa (kgf/cm ²)	Kg
2-080	78	850	850	235 (24)	343 (35)	20.6 (210)	30.9 (315)	6.9 (70)	9.6
2-100	97	690	850	284 (29)	383 (39)	20.6 (210)	27.4 (280)	6.9 (70)	9.8
2-125	123	550	690	324 (33)	392 (40)	18.1 (185)	22.1 (225)	6.9 (70)	10.1
2-160	158	430	540	334 (34)	471 (48)	14.7 (150)	20.6 (210)	6.9 (70)	10.4
2-200	195	350	440	373 (38)	520 (53)	13.2 (135)	18.6 (190)	6.9 (70)	10.8
2-250	244	280	350	373 (38)	579 (59)	10.8 (110)	16.7 (170)	6.9 (70)	11.3
2-290	288	250	300	422 (43)	608 (62)	10.3 (105)	14.7 (150)	6.9 (70)	11.8
2-315	306	230	280	432 (44)	608 (62)	9.8 (100)	13.7 (140)	6.9 (70)	12.0
2-390	393	190	230	441 (45)	638 (65)	7.8 (80)	11.3 (115)	6.9 (70)	13.0

Note: 1. Intermittent: 10% of every minute, Maximum: 1% of every minute, operation available..

2. Continuous Pressure, Maximum Pressure: Show true pressure difference between motor inlet and out let ports. Maximum pressure at the motor inlet port of 30.9MPa (315kgf/cm²), out let port of 17.2MPa (175kgf/cm²)

3. Because there is a torque by each output shaft type, use within the torque.

4. A simultaneous Intermittent Speed and Maximum Pressure condition must not occur.

5. Weight: Show the weight of Standard Motor.

Sectional view

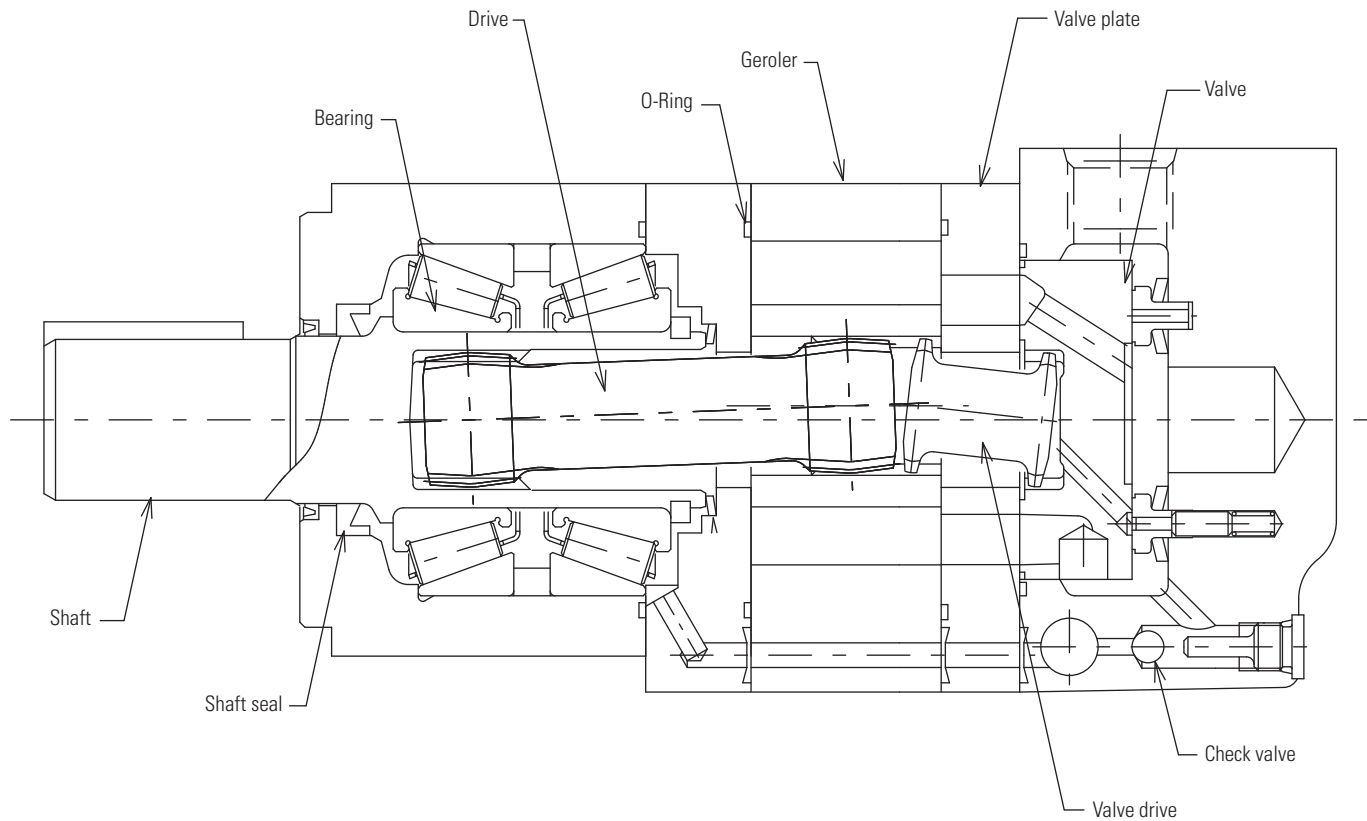

2000 Series

Performance data

The performance data on this catalogue show the typical Torque Efficiency and Volume Efficiency of 2000 series motors at each pressure at 34 cSt.

Note: These data are not guaranteed data.

2 - 080 (78cm³/rev)

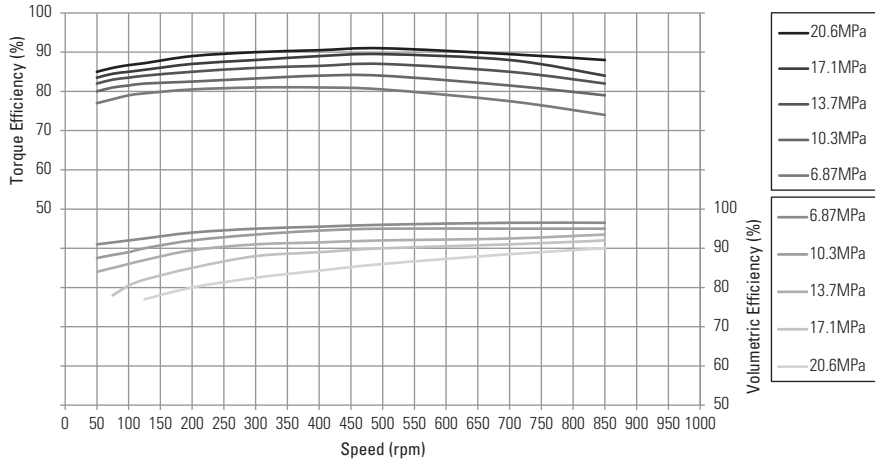

2 - 100 (97cm³/rev)

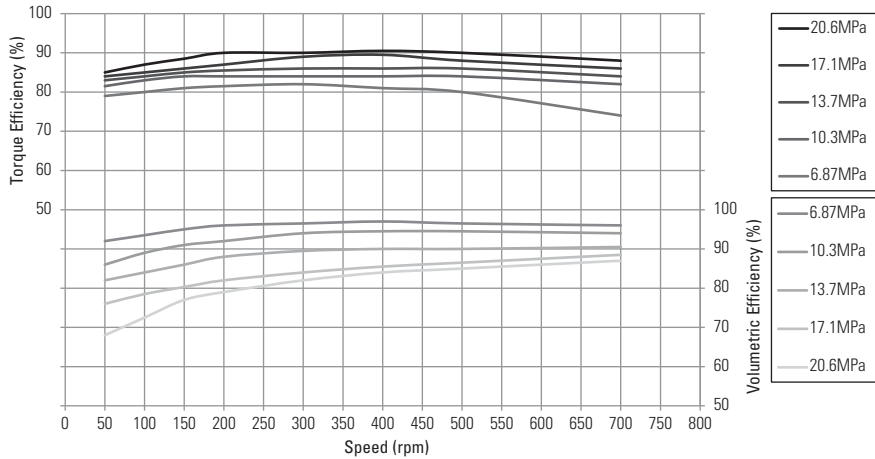

2000 Series

2 - 125 (123cm³/rev)

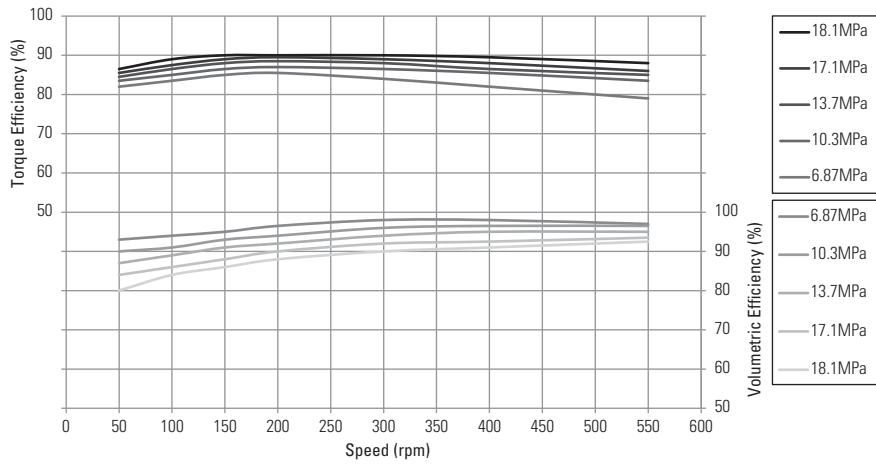

2 - 160 (158cm³/rev)

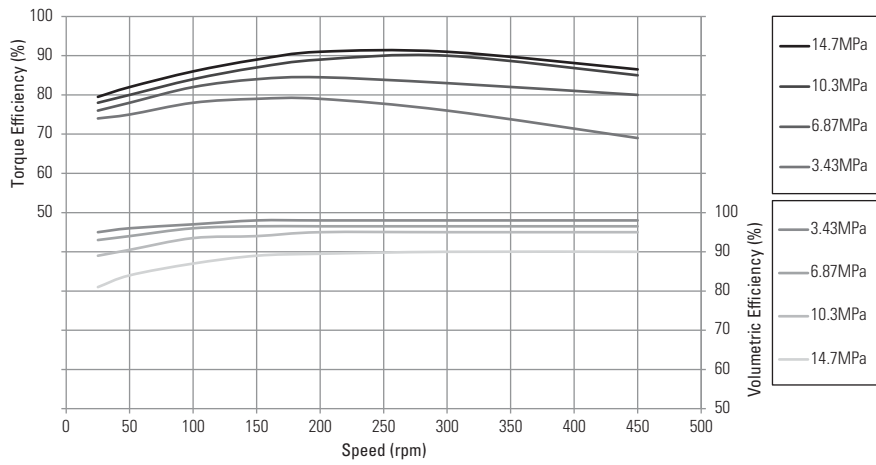

2 - 200 (195cm³/rev)

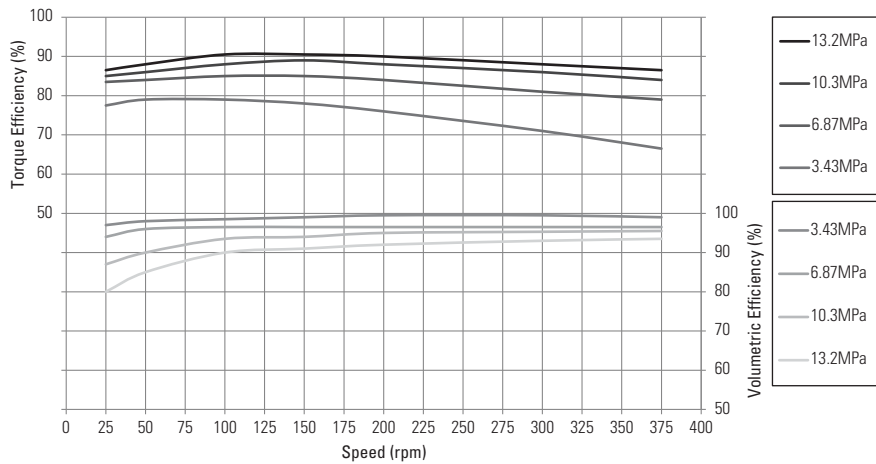

2000 Series

2 - 250 (244cm³/rev)

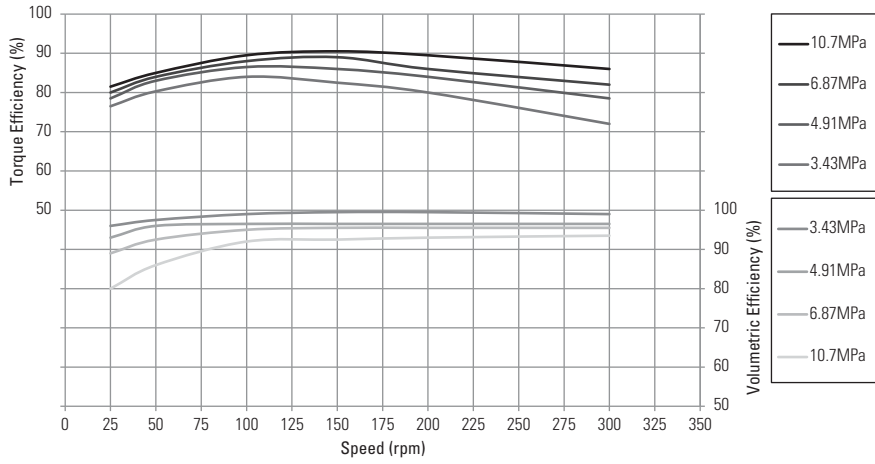

2 - 290 (288cm³/rev)

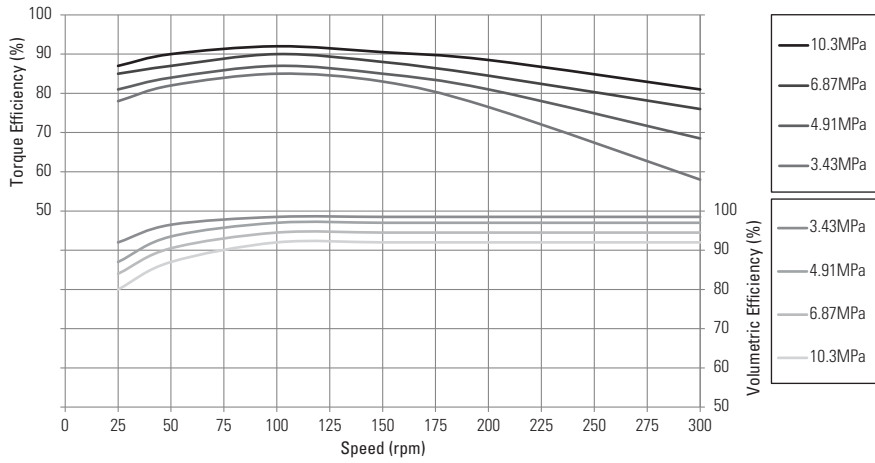

2000 Series

2 - 315 (306cm³/rev)

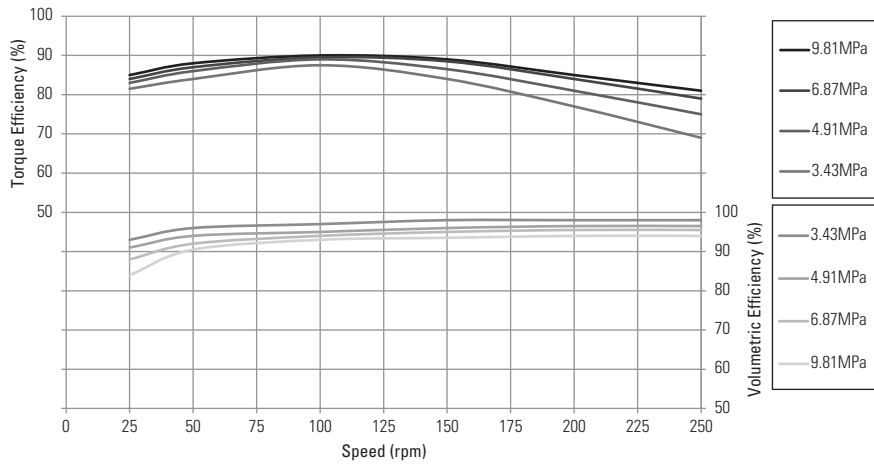

2 - 390 (393cm³/rev)

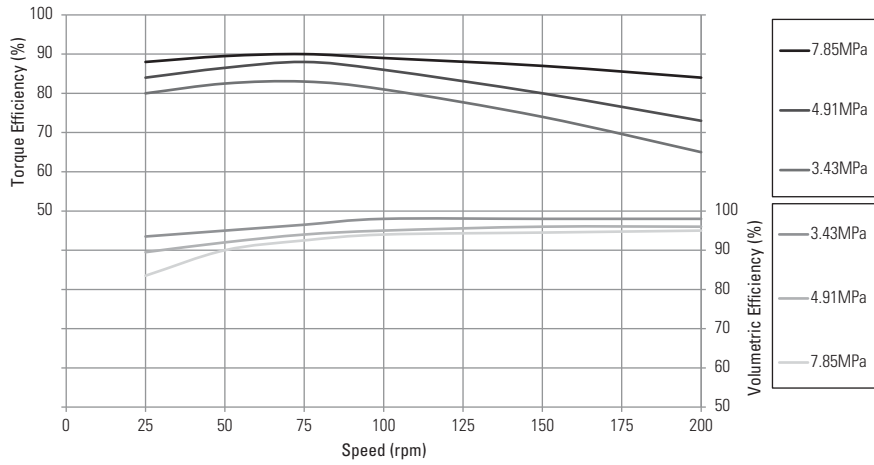

2000 Series

Dimensions and mounting data (side port)

Rotation: Viewed from shaft end

- CW: Port A pressurized
- CCW: Port B pressurized

Standard motor

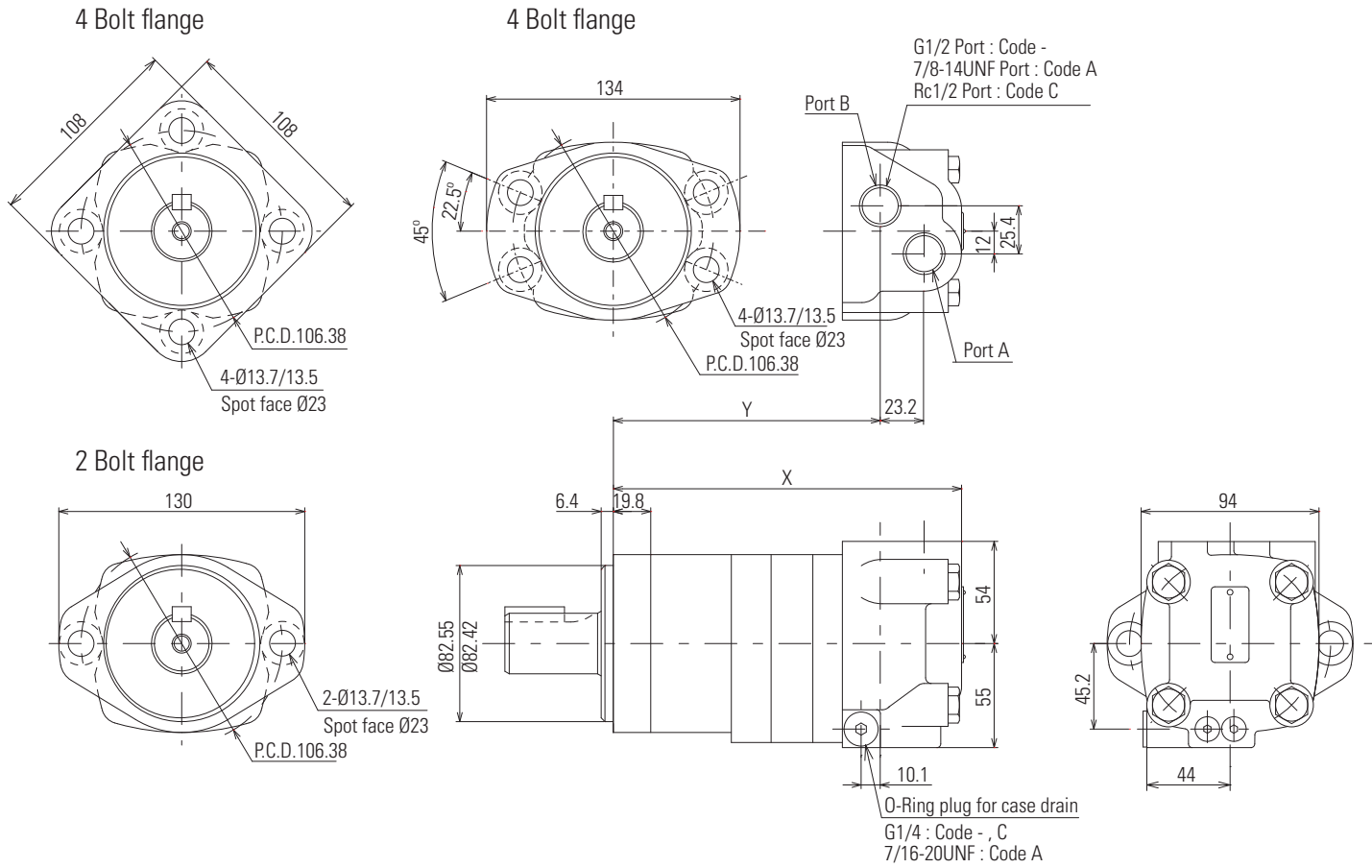

Model	2-080	2-100	2-125	2-160	2-200	2-250	2-290	2-315	2-390
X	176	180	185	191	198	207	215	218	234
Y	133	137	142	148	155	164	172	175	191

2000 Series

Wheel motor

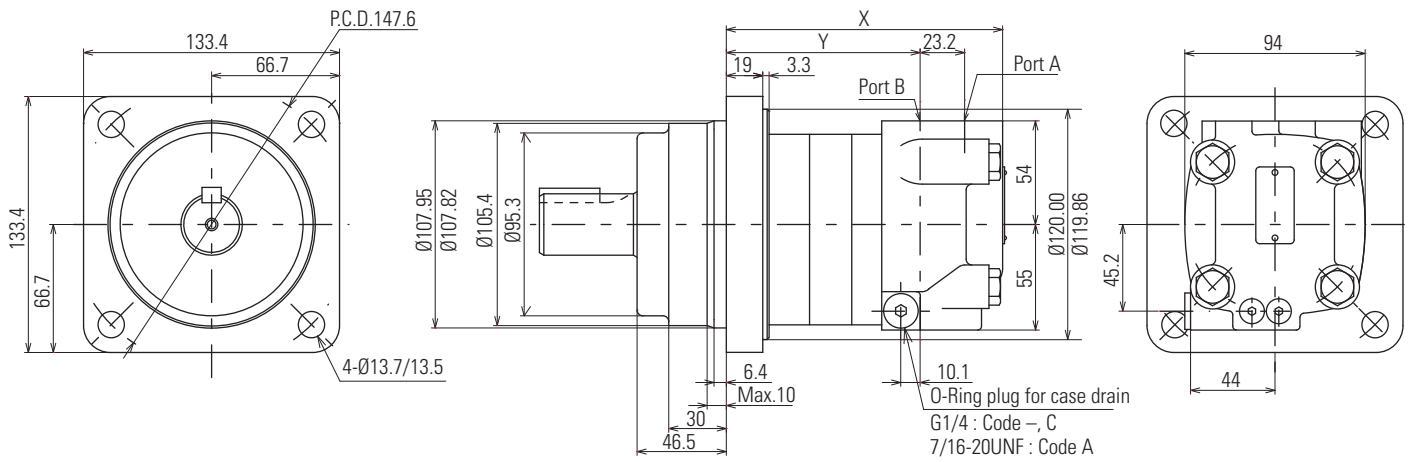

Model	2-080	2-100	2-125	2-160	2-200	2-250	2-290	2-315	2-390
X	136	140	144	151	157	167	175	178	194
Y	93	97	101	108	114	124	132	135	151

2000 Series

Dimensions and mounting data (wide side port)

Rotation: Viewed from shaft end

- CW: Port A pressurized
- CCW: Port B pressurized

Standard motor

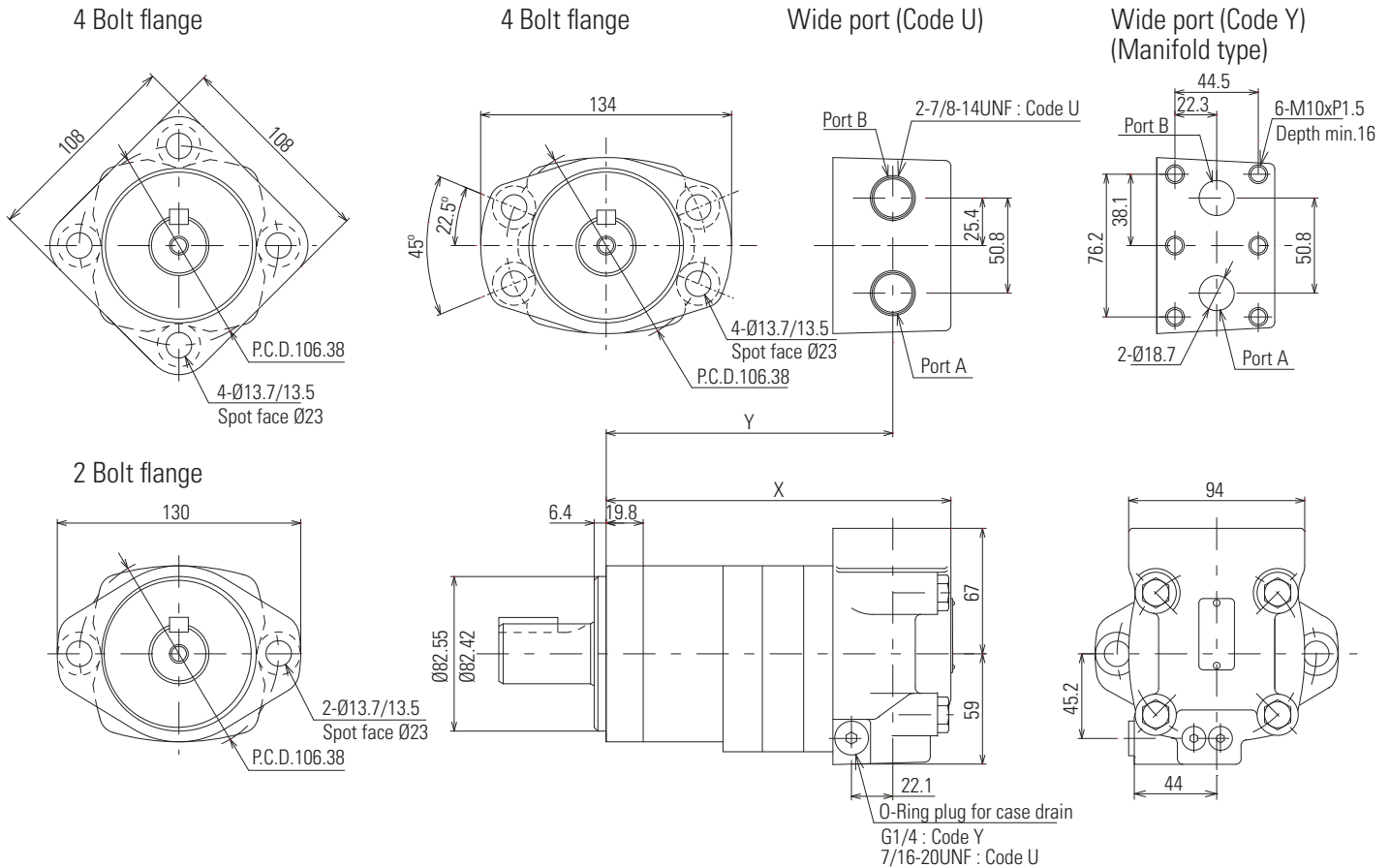

Model	2-080	2-100	2-125	2-160	2-200	2-250	2-290	2-315	2-390
X	176	180	185	191	198	207	215	218	234
Y	145	149	154	160	167	176	184	187	203

2000 Series

Wheel motor

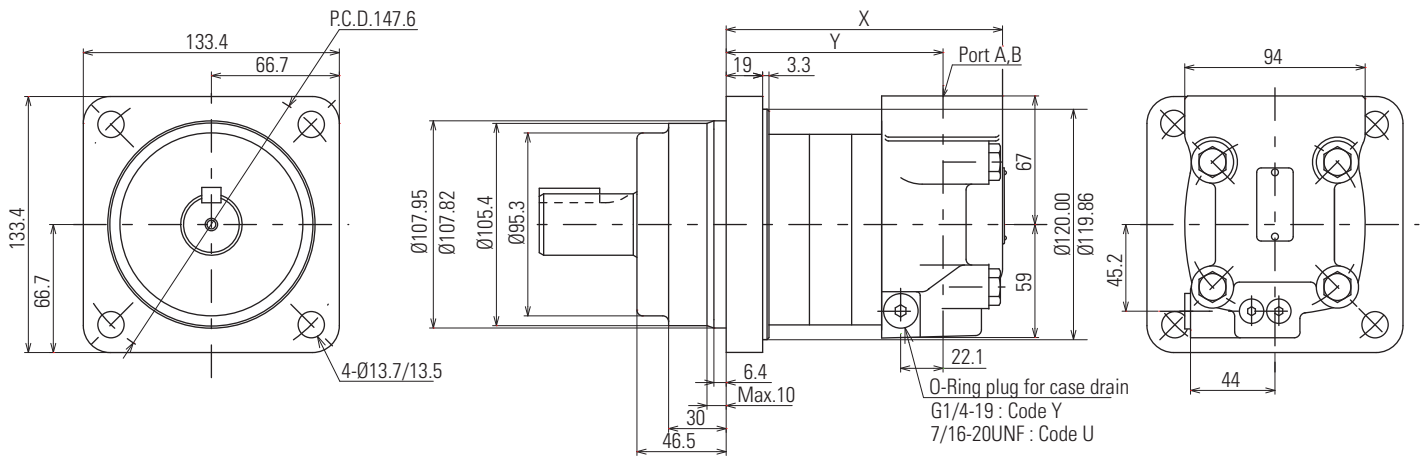

Model	2-080	2-100	2-125	2-160	2-200	2-250	2-290	2-315	2-390
X	136	140	144	151	157	167	175	178	194
Y	105	109	113	120	126	136	144	147	163

2000 Series

Dimensions and mounting data (rear port)

Rotation: Viewed from shaft end

- CW: Port A pressurized
- CCW: Port B pressurized

Standard motor

4 Bolt flange

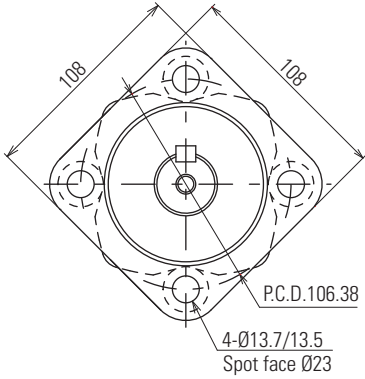

4 Bolt flange

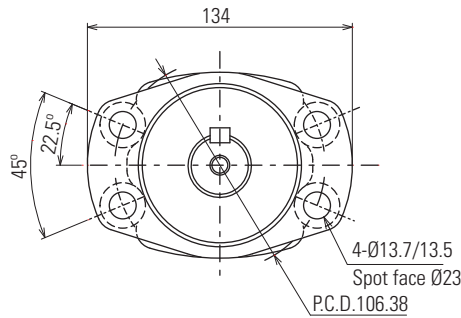

2 Bolt flange

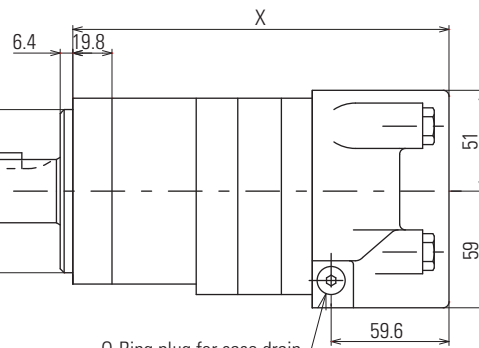
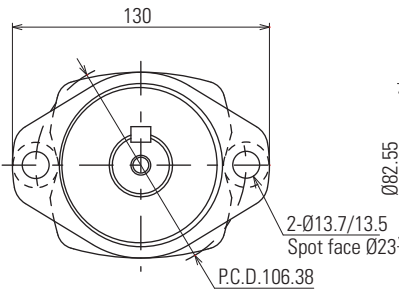

O-Ring plug for case drain
G1/4: Code B8
7/16-20UNF: Code D

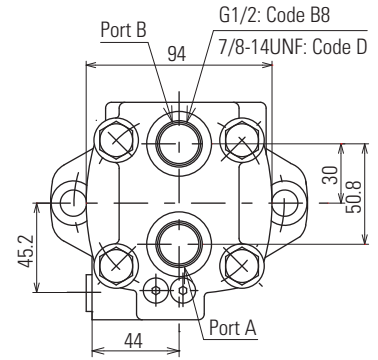

Model	2-080	2-100	2-125	2-160	2-200	2-250	2-290	2-315	2-390
X	183	186	191	197	204	213	221	225	241

2000 Series

Dimension data for shaft

Shaft code: J
Ø32" Straight shaft

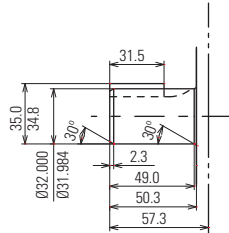
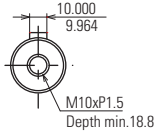

Shaft code: B
1-1/4" Involute splined shaft

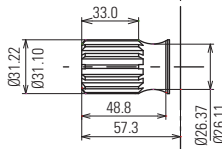
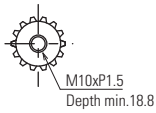

Shaft code: C
1-1/4" Tapered shaft (SAE) Taper: 1.5/12

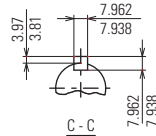
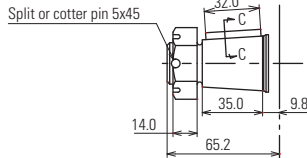
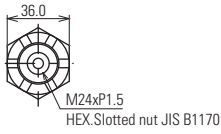

Shaft code: D
1-1/4" Straight shaft

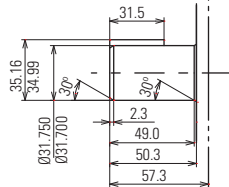
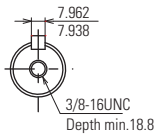

Recommended shaft hole size

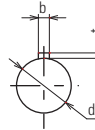

Shaft code: E
Ø1" Straight shaft (Max. Torque 395 N-m)

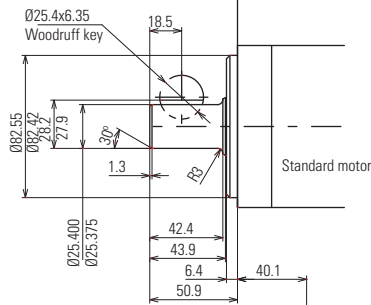
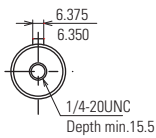

Standard motor

Wheel motor

1-1/4" SAE Involute Spline (External)

D.P	12/24
Number of teeth	14
Pitch Dia.	29.634
Base Dia.	25.664
Pressure angle	30°
Type of fit	Side fit
Class of fit	II
Major Dia.	31.22/31.10
Minor Dia.	26.99/26.66
Form Dia.	Max. 27.488
Fillet radius	Max. 0.39
Dimension over two pins	35.797/35.750
Pin Dia.	4.064

Shaft	d	b	t
J	32.00 +0.025 0	10.000 ± 0.018	3.2 + 0.2 0
B	Please reference internal spline		
C	—	7.962 + 0.036 0	4.1 + 0.2 0
D	31.75 + 0.025 0	7.962 + 0.036 0	3.6 + 0.2 0
E	25.4 + 0.021 0	6.375 + 0.036 0	2.9 + 0.2 0

SAE Involute Spline (Internal)

D.P	12/24
Number of teeth	14
Pitch Dia.	29.634
Base Dia.	25.664
Pressure angle	30°
Type of fit	Side fit
Major Dia.	32.08/31.75
Minor Dia.	27.72/27.59
Form Dia.	Min. 31.326
Dimension over two pins	24.407/24.342
Pin Dia.	3.6576

Instruction

Instruction for use

Permissible back pressure

The motors have an internal check valve system, and it becomes the internal case drain. The case internal pressure becomes the same as either of A or B port low pressure. This pressure is the back pressure.

Use to maintain the life of shaft seal long under continuous pressure 1.96MPa (20kgf/cm²) and peak maximum pressure 6.9MPa (70kgf/cm²).

When using equal to or more than two motors in series, or the high back pressure operates like the meter out control, the external drain line is necessary.

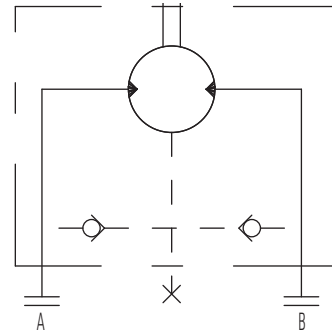

Radial load capacity

These curves indicate the radial load capacity of the 2000 Series Standard and Wheel Motor depending on the location of the radial load. The curves are based on 2000 hr. B-10 bearing life at 100rpm and at rated output torque. To determine the allowable radial load at speeds other than 100rpm, multiply the load values given on the bearing curves by the factors given in the chart. External thrust load can be applied by maximum 4500N either direction simultaneously.

**Allowable Side Load
(1" straight shaft)**

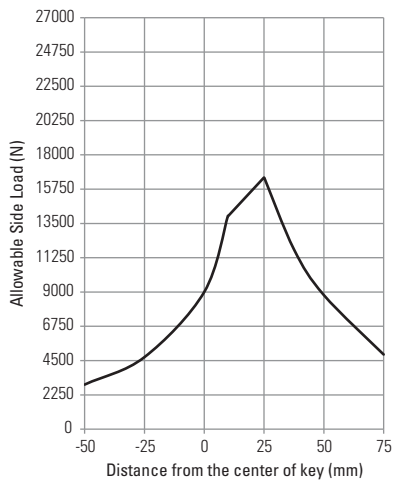

**Allowable Side Load
(1-1/4", 32mm straight shaft)**

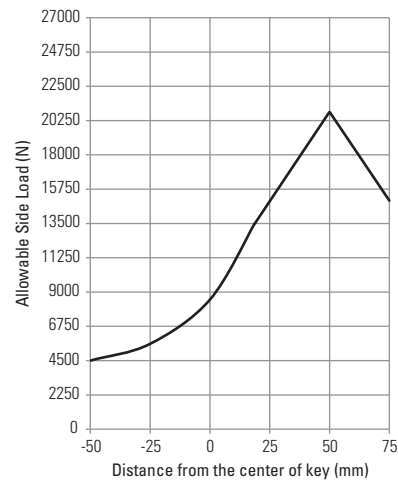

Distance from key center

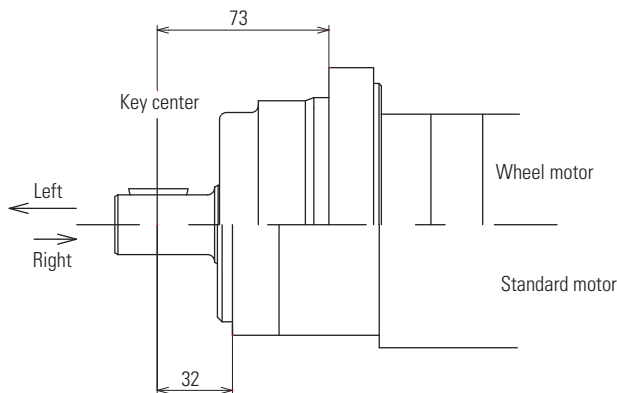

Ø1" Straight shaft

Distance from key center

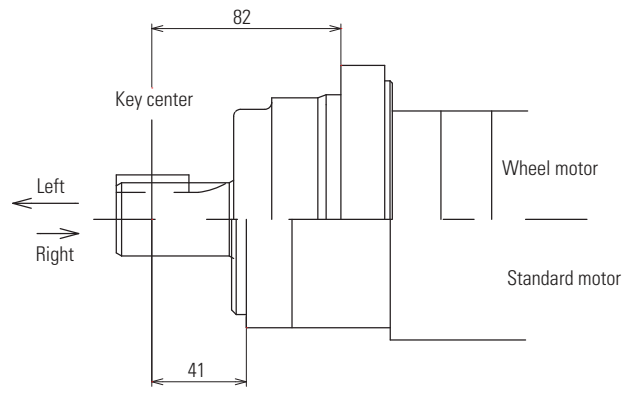

1-1/4", Ø32" Straight shaft

Instruction

**Allowable Side Load
(1-1/4", Involute splined shaft)**

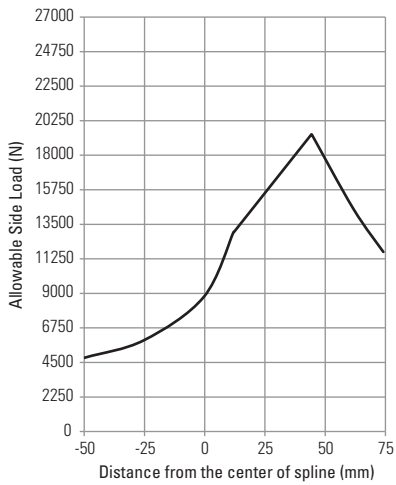

**Allowable Side Load
(1-1/4", Tapered shaft)**

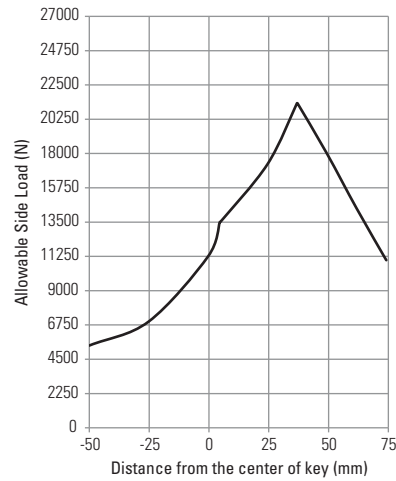

Distance from spline center

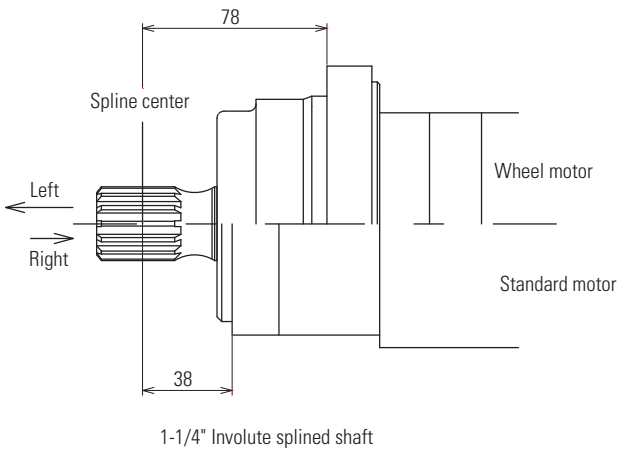

Distance from key center

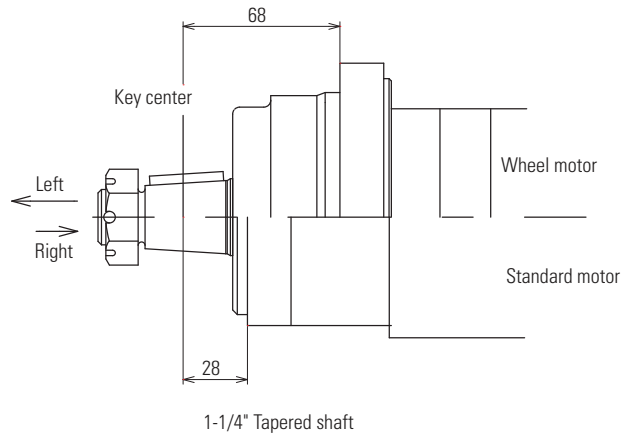

rpm	Multiplication Factor
050	1.23
100	1.00
200	0.81
300	0.72
400	0.66
500	0.62
600	0.58
700	0.56
800	0.54

Instruction

Hydraulic fluid

Recommended Fluid; Mineral based Anti-Wear Hydraulic Fluid ISO VG32, VG46, VG56, VG68, or equivalent fluid

Allowable Fluid Temperature Range; from -30 to +80 degrees C.

Recommended Viscosity Range; from 24 to 50 cSt

The allowable lowest viscosity; 13 cSt (for H series ; 20 cSt)

The allowable highest viscosity; 2158 cSt

Recommended Filtration; 10 micron or finer

Fluid Cleanness; ISO 18/13 or finer

Note: If the motor is used with special fluid such as flame-resistant fluid, please contact Eaton because special seals etc. are needed.

Inertia load application, etc.

When the motor is used in the inertia load application such as swing drive, it is necessary to use the brake valve in order to protect the motor and its shaft.

When the motor acts as a pump in the winch drive application or down-slope travel application, it is often necessary to use the counter balance valve in order to prevent the circuit cavitation or reckless driving by the self-weight.

In these cases, please contact Eaton for details.

Valves for 2000 Series

V2A Brake valve for direct connection (for side port)

<Features> Total system will be designed economically because this can be connected directly with 2000 series motor. This valve prevents an irregular high pressure by inertia load at accelerating, decelerating and stopping and then safe operation is ensured.

<Specifications> Rated Flow: 30l/min
 Pressure Range: 6.9~20.6MPa (70~210kgf/cm²)
 Weight: 1.4kg

V2A Pressure Override Performance

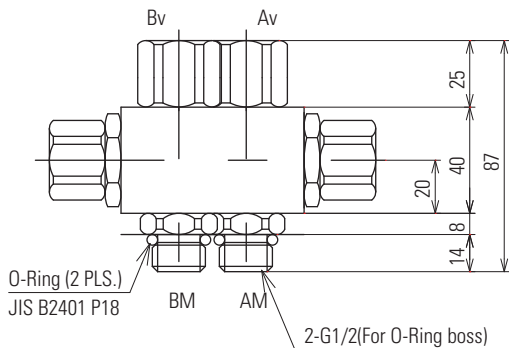
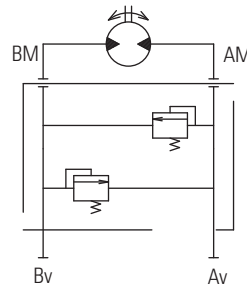
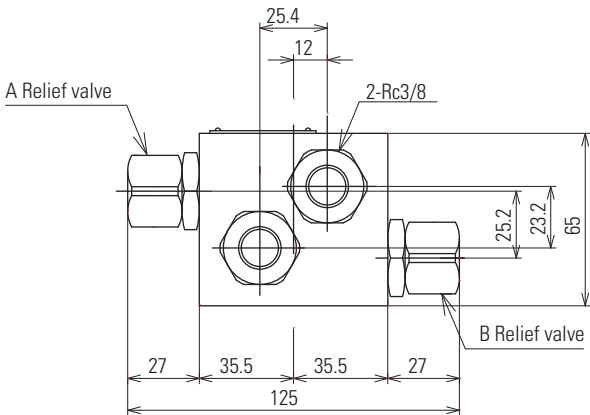
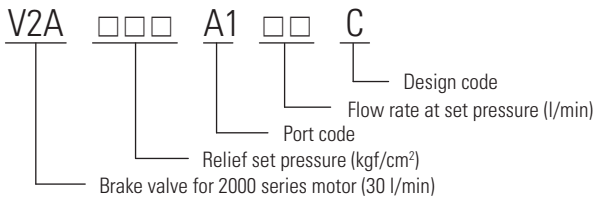
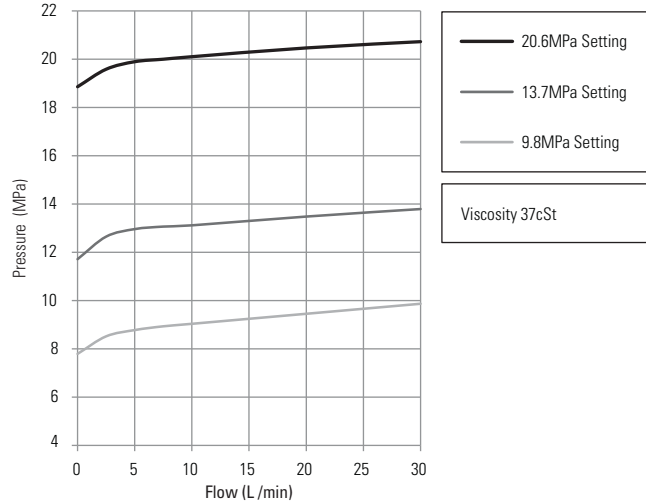

Valves for 2000 Series

V2B Counter balance valve for direct connection (for side port)

<Features> Total system will be designed economically because this can be connected directly with 2000 series motor. This can be connected directly with direct connected brake valve. The circuit cavitation or reckless driving by the self-weight can be prevented.

<Specifications> Max. Pressure: 20.6MPa (210kgf/cm²)
 Rated Flow: 30l/min
 Spool Cracking Pressure: 0.5MPa (5kgf/cm²)
 Weight: 3.4kg

V2B Pressure Drop Performance

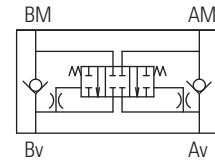
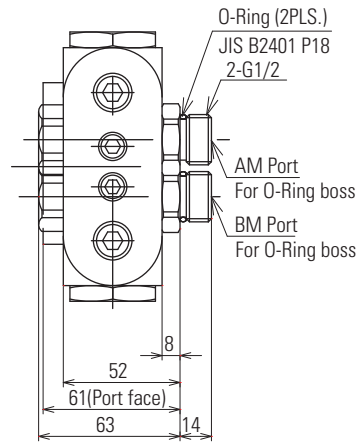
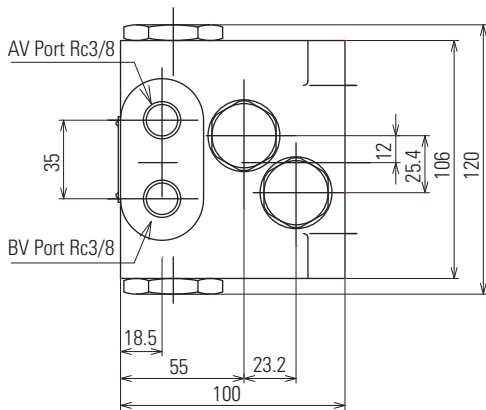
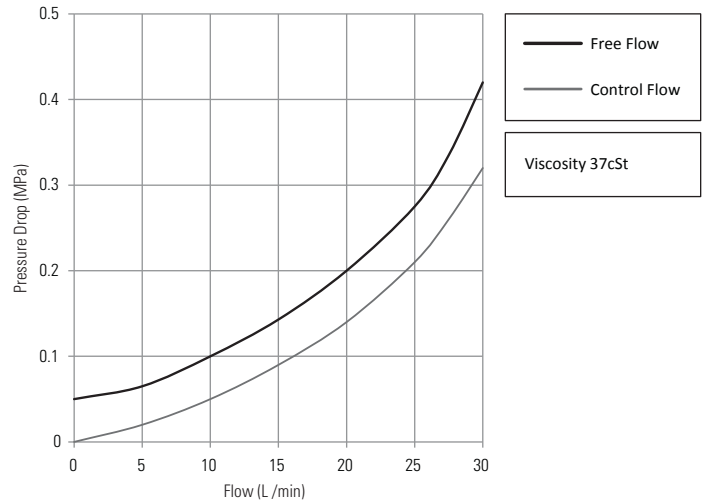

Valves for 2000 Series

V2L Brake valve for direct connection

<Features> Total system will be designed economically because this can be connected directly with 2000 series motor. This valve prevents an irregular high pressure by inertia load at accelerating, decelerating and stopping and then safe operation is ensured.

<Specifications> Rated Flow: 60l/min
 Pressure Range: 6.9~20.6MPa (70~210kgf/cm²)
 Weight: 4.4kg

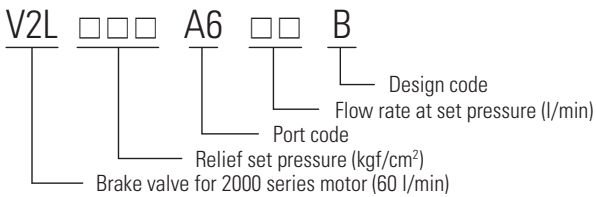

V2L Pressure Override Performance

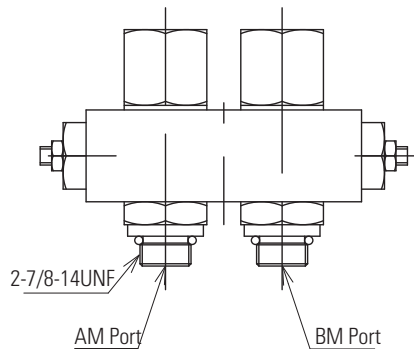
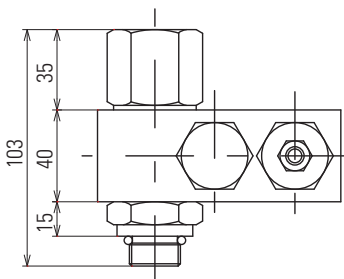
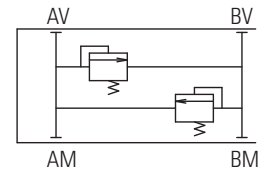
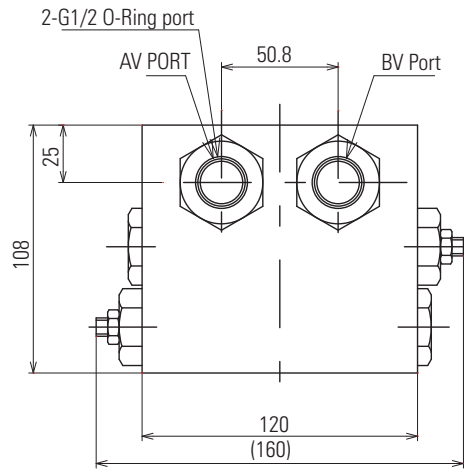
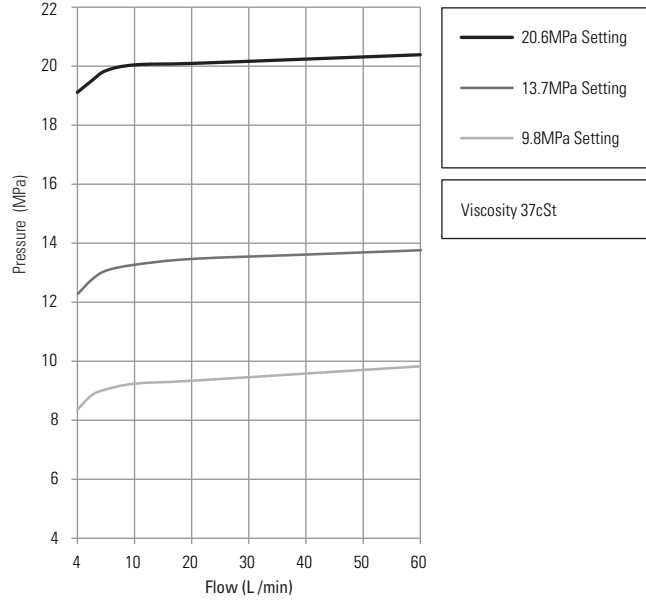

Valves for 2000 Series

V2M Counter balance valve for direct connection (for side port)

<Features> Total system will be designed economically because this can be connected directly with 2000 series motor. This can be connected directly with direct connected brake valve. The circuit cavitation or reckless driving by the self-weight can be prevented.

<Specifications> Max. Pressure: 20.6MPa (210kgf/cm²)
 Rated Flow: 60l/min
 Spool Cracking Pressure: 0.6MPa (6kgf/cm²)
 Weight: 3.8kg

V2M Pressure Drop Performance

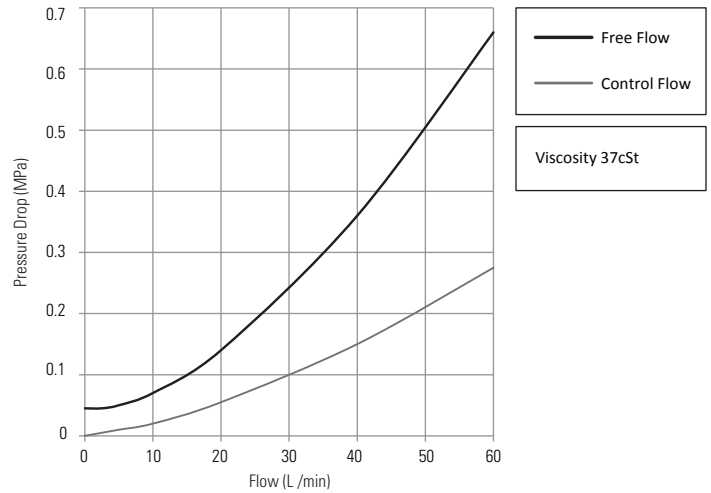

V2M A6 A
 Counter balance valve for 2000 series motor (60 l/min)
 Design code
 Port code

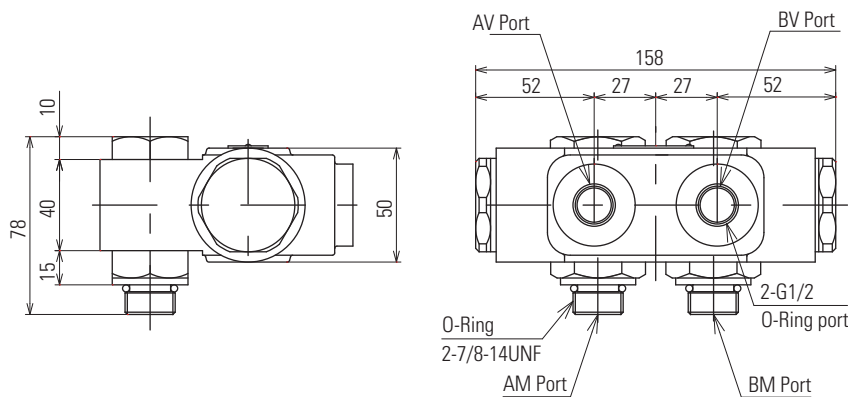
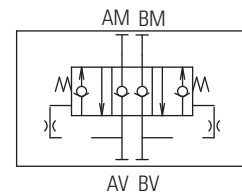
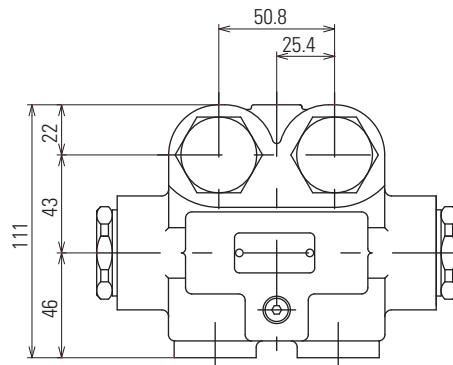

S Series Motor with Mechanical Brake

Features

S Series Motor with a compact type mechanical brake built-in. The motor can be used widely in the fields of construction machines, fishing machines, industrial vehicles, general industrials, etc.

Braking can be applied when the pilot pressure is not supplied. In case of SBD and SBE, mechanical releasing of brake is possible.

- Brake releasing by pressure (SBA, SBD, SBE, SBF)

SBA,SBF Series

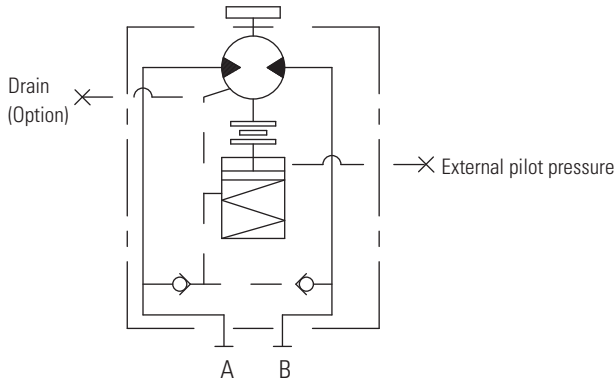

SBD,SBE Series

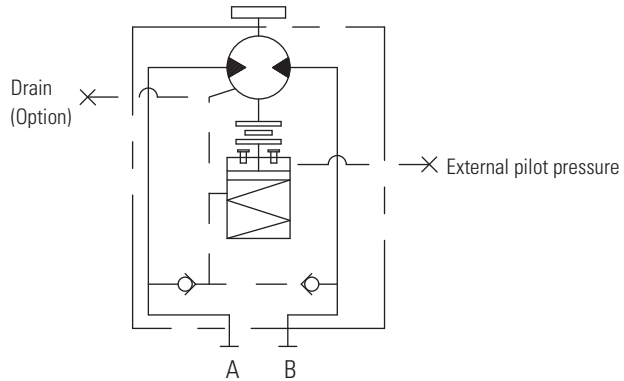

Specifications

Series	Brake Torque	Brake Release Pressure	Brake Release System
SBA	98N-m (10kgf-m)	1.0MPa (10kgf/cm ²)	External Pilot
SBD	98N-m (10kgf-m)	1.0MPa (10kgf/cm ²)	External Pilot + Mechanical System
SBE	157N-m (16kgf-m)	1.6MPa (16kgf/cm ²)	External Pilot + Mechanical System
SBF	157N-m (16kgf-m)	1.6MPa (16kgf/cm ²)	External Pilot

- Note: 1. Other specifications are same as Standard S Series motor.
 2. Fire resistant fluid need special specification motor. Please contact with our company.
 3. This Brake can be used as a Parking Brake only. In case of dynamic brake application, please contact Eaton.

S Series Motor with Mechanical Brake

Model code procedure

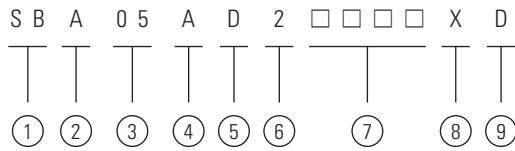

① **Series**
SB = S Series motor with mechanical brake

② **Brake specifications**
A = External pilot, 98N-m
D = External pilot + Mechanical release system, 98N-m
E = External pilot + Mechanical release system, 158N-m
F = External Pilot, 158N-m

③ **Displacement (cm³/rev)**
05 = 58
07 = 76
10 = 93
12 = 120
14 = 144
16 = 165
19 = 186
22 = 224
30 = 299
38 = 371

④ **Port**
A = G1/2 O-Ring ports
B = Manifold mount
C = 1/2NPTF Ports
D = Rc1/2 Ports

⑤ **Shaft**
B = Ø1" SAE 6B Splined shaft
C = Ø1" Straight with Woodruff key
D = Ø25 Straight with Parallel key, 8mm

⑥ **Flange mounting**
2 = 2 Bolt
4 = 4 Bolt

⑦ **Special features (none of standard motor)**
B = Special seal for Phosphate ester fluid
M = Metric mounting holes

⑧ **Drain port**
x = Standard, with Drain port

⑨ **Design code**
D = Model D

How to release the brake mechanically

The SBD and SBE Series are provided with a mechanical type brake releasing mechanism.

- Remove the (2) gaskets and alternately tighten two brake releasing plugs. The brake will be released mechanically.
- To restore braking, insert the gaskets and tighten the brake releasing plugs at a torque of 25.5~31.4N-m (At this time, clean the surface of sealing).

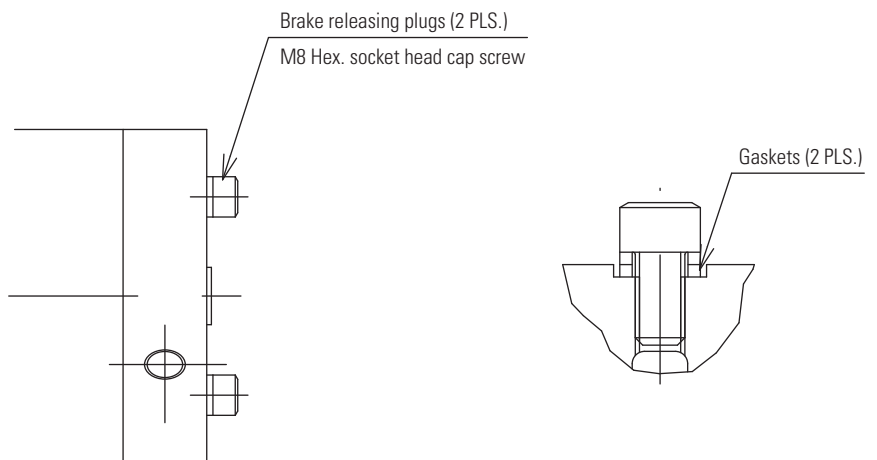

S Series Motor with Mechanical Brake

Dimension and mounting data

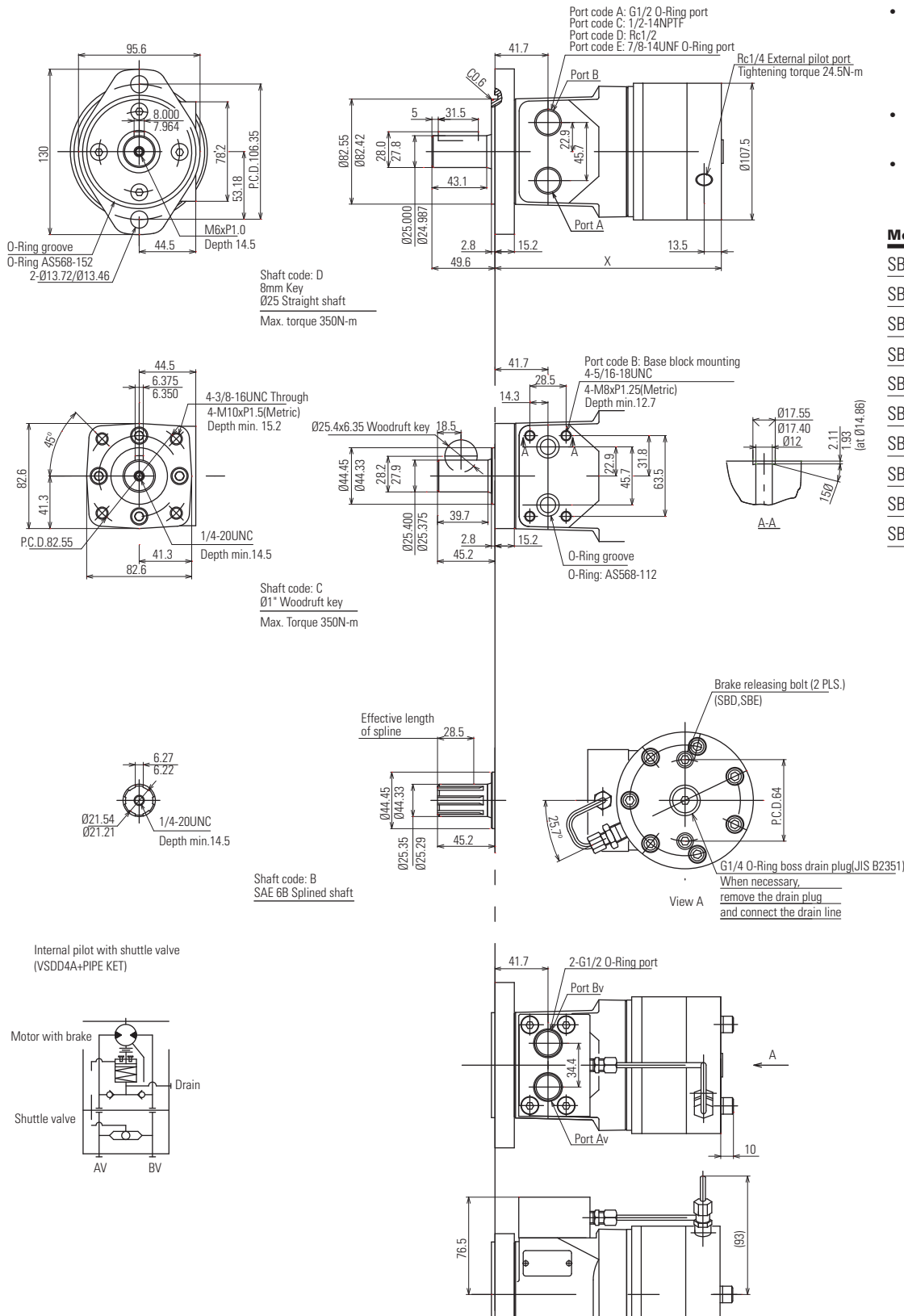

- Rotation: Viewed from shaft end
- CW: Port A pressurized
- CCW: Port B pressurized
- Need to select the port code B with metric 4-M8 thread
- A change coupler of Rc3/8 is available (AH0039A)

Model	X: Length
SB□05	177.0
SB□07	179.3
SB□10	181.5
SB□12	184.9
SB□14	188.1
SB□16	190.7
SB□19	193.4
SB□22	198.3
SB□30	208.0
SB□38	217.3

2000 Series Motor with Mechanical Brake (Brake Torque 98-196N-m)

Features

This Series has a pressure-release mechanical brake built in the motor. Secure control of start and stop is possible because the brake is applied when pilot pressure is not supplied. Applications: Fishing Machines, Various Winches, Industrial Vehicles, Various Industrial Machines.

Specifications

Model Code	Brake Torque	Brake Release Pressure	Brake Release System
2-□□□K□□-E	98N-m (10kgf-m)	0.98MPa (10kgf/cm ²)	External Pilot
2-□□□M□□-E	196N-m (20kgf-m)	1.96MPa (20kgf/cm ²)	External Pilot
2-□□□L□□-E	98N-m (10kgf-m)	0.98MPa (10kgf/cm ²)	Internal Pilot
2-□□□N□□-E	196N-m (20kgf-m)	1.96MPa (20kgf/cm ²)	Internal Pilot

Note: 1. Other specifications are same as Standard 2000 Series motor.
2. This Brake can be used as a Parking Brake only. In case of dynamic brake application, please contact Eaton.

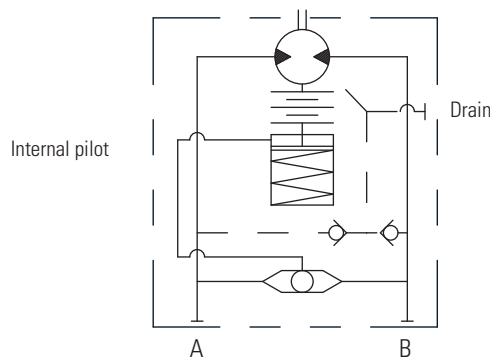
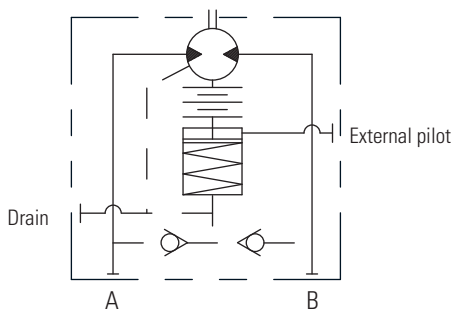

Model code procedure

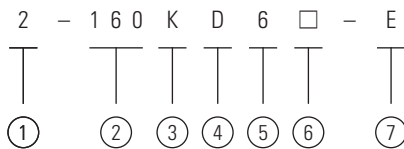

- | | |
|---|--|
| <p>① Series
2 = 2000 series</p> <p>② Displacement (cm³/rev)</p> <p>③ Brake Torque
K = 98N-m, External pilot
M = 196N-m, External pilot
L = 98N-m, Internal pilot
N = 196N-m, Internal pilot</p> <p>④ Shaft
A = Ø32 Straight with 10x8x31.5 Key
B = Ø1-1/4" Splined
D = Ø1-1/4" Straight with 5/16" Square key
F = Ø1" Straight with 1/4" Key</p> | <p>⑤ Flange mounting
2 = 2 Bolt
6 = 4 Bolt (unequally spaced)</p> <p>⑥ Port connections
None = G1/2 O-Ring ports
A = 7/8UNF Side ports
C = Rc1/2 Side ports
U = 7/8UNF Side ports (pitch 50.8mm)</p> <p>⑦ Design code
E = Model E</p> |
|---|--|

2000 Series Motor with Mechanical Brake (Brake Torque 98-196N-m)

Dimension and mounting data

External pilot pressure

Rotation: Viewed from shaft end

• CW: Port A pressurized

• CCW: Port B pressurized

Ø32 Straight shaft

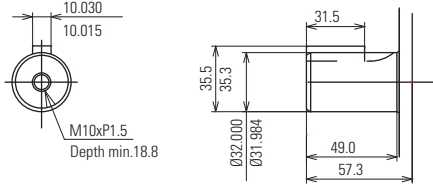

Model	X	Y
2-080	229	186
2-100	232	189
2-125	237	194
2-160	243	200
2-200	250	207
2-250	259	216
2-290	267	224
2-315	271	228
2-390	286	243

1-1/4" SAE Involute Spline (External)

D.P	12/24
Number of teeth	14
Pitch Dia.	29.634
Base Dia.	25.664
Pressure angle	30°
Type of fit	Side fit
Class of fit	II
Major Dia.	31.22/31.10
Minor Dia.	26.99/26.66
Form Dia.	Max. 27.488
Fillet radius	Max. 0.39
Dimension over two pins	35.797/35.750
Pin Dia.	4.064

Ø1-1/4" Involute splined shaft

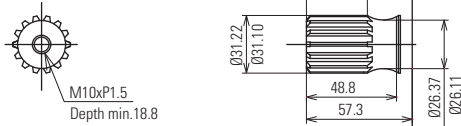

Ø1-1/4" Straight shaft

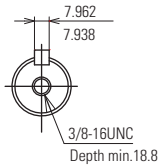

Ø1" Straight shaft

4 Bolt flange

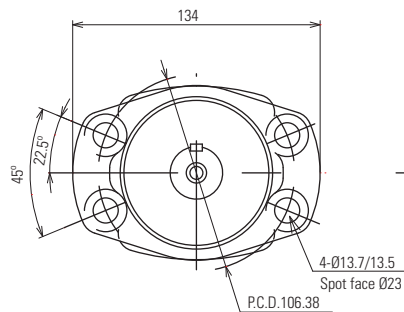

2 Bolt flange

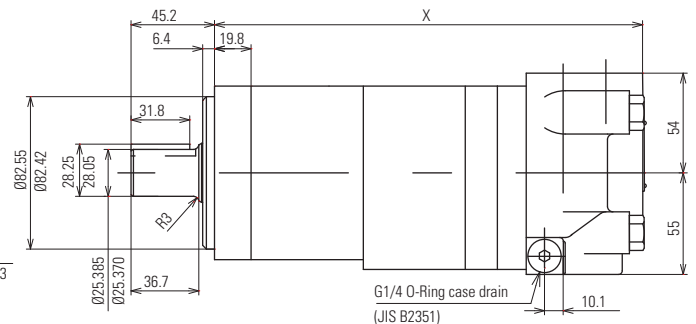
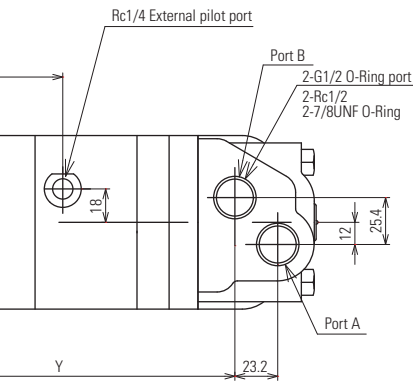
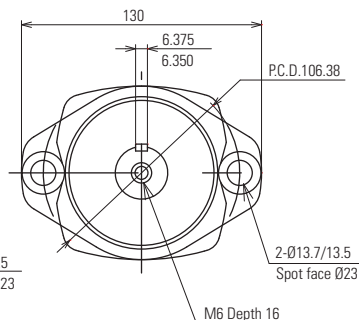

2000 Series Motor with Mechanical Brake (Brake Torque 294-392N-m)

Specifications

Model Code	Brake Torque	Brake Release Pressure	Brake Release System
2BE□□A□4□-B	294N-m (30kgf-m)	2.0MPa (20kgf/cm ²)	External Pilot
2BF□□A□4□-B	392N-m (40kgf-m)	2.5MPa (26kgf/cm ²)	External Pilot

Note: 1. This Brake can be used as a Parking Brake only. In case of dynamic brake application, please contact Eaton.

Model code procedure

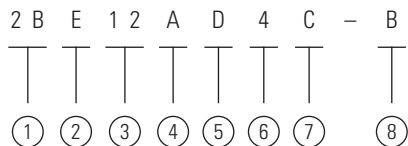

① **Series**
2B = 2000 Series with mechanical brake

② **Brake Torque**
E = 294N-m, External pilot
F = 392N-m, External pilot

③ **Displacement (cm³/rev)**
08 = 78
10 = 97
12 = 123
16 = 158
20 = 195
25 = 244
29 = 288
31 = 306
39 = 393

④ **Motor type**
A = Standard

⑤ **Shaft**
A = Ø32 Straight with 10x8x31.5 Key
B = Ø1-1/4" Splined
C = Ø1-1/4" Tapered
D = Ø1-1/4" Straight with 5/16" Square key

⑥ **Flange mounting**
4 = 4 Bolt (P.C.D. 127)

⑦ **Port connections**
None = G1/2 O-Ring ports
C = Rc1/2 Side ports

⑧ **Design code**
B = Model B

2000 Series Motor with Mechanical Brake (Brake Torque 294-392N-m)

Dimension and mounting data

External pilot pressure

Ø1-1/4" Involute splined shaft

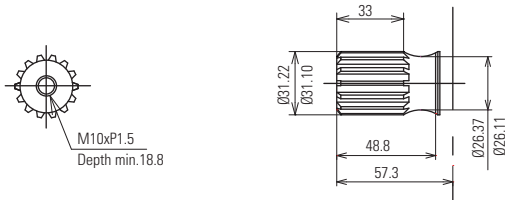

Ø1-1/4" Tapered shaft (SAE Taper: 1.5/12)

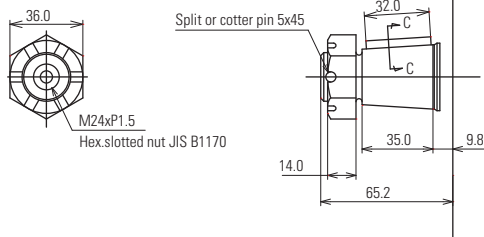

Ø32 Straight shaft

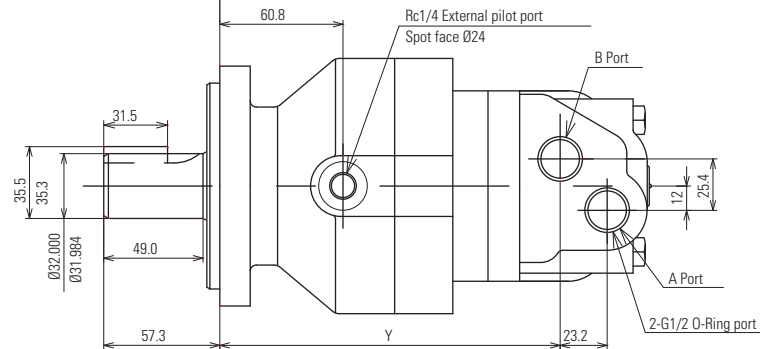
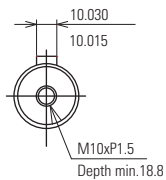

Ø1-1/4" Straight shaft

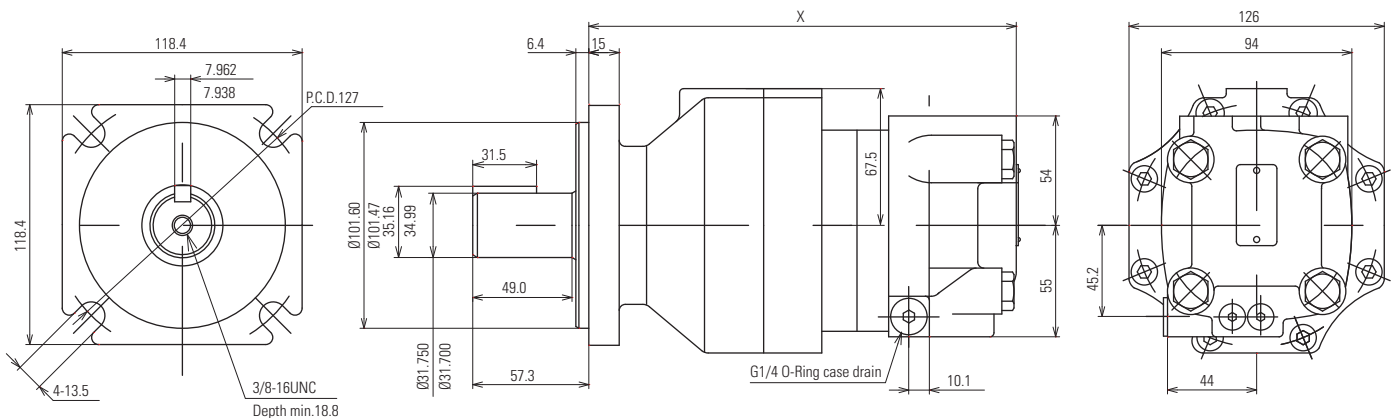

Rotation: Viewed from shaft end

- CW: Port A pressurized
- CCW: Port B pressurized

Model	X	Y
2BF08	208	165
2BF10	211	168
2BF12	216	173
2BF16	223	180
2BF20	229	186
2BF25	238	195
2BF29	246	203
2BF31	250	207
2BF39	266	223

1-1/4" SAE Involute Spline (External)

D.P	12/24
Number of teeth	14
Pitch Dia.	29.634
Base Dia.	25.664
Pressure angle	30°
Type of fit	Side fit
Class of fit	II
Major Dia.	31.22/31.10
Minor Dia.	26.99/26.66
Form Dia.	Max. 27.488
Fillet radius	Max. 0.39
Dimension over two pins	35.797/35.750
Pin Dia.	4.064

Orbit Motor, Optional Products

S Series motor with Pin brake

- The brake is of a simplified parking brake type, especially developed for use on track-mounted slewing cranes. Compared with conventional disk brake, the pin brake is much simple in construction and available with a low price.
- Applications : Construction Machine, Material Handling

S Series motor with rotation detecting shaft

- Because of their rotation detecting shaft, this series of Orbit Motors are suited to usage in combination with such as tachometers and encoders. We recommend them for use in injection molding machines needing rpm detection and in robot machines needing rpm-based control.
- Applications : Plastic Injection Machine, Industrial Machine and Mobile

2000 Series motor with rotation detecting shaft

- By the rotation detecting shaft, these motors are especially adapted to combination with tachometers, encoders and the like. In particular, Injection molding machines needing rpm detection will find the most convenient detecting in these motors.
- Applications : Plastic Injection Machine, Industrial Machine and Mobile

Orbit motor with GJ type planetary-gear reducer

- The motors of this series are combinations of H, S, 2000 Series Motor and planetary-gear reducer. The reducer shaft, not frame, is the driving member.
- Applications : Industrial Machines, Fishing Machines

Orbit motor with GW type planetary-gear reducer

- The motors of this series are intended for use driving travelling mechanism and winches, each being a combination of 2000 Series Motor and planetary-gear reducer. The reducer frame is the driving member.
- Applications : Construction Machines, Agricultural and Forestry Machines, Fishing Machines



Direct Mount Valves

Valve Type	Model	Rated Flow l/min	Max. Working Pressure MPa (kgf/cm ²)	Adjustable Pressure Range MPa (kgf/cm ²)	Host Orbit Motor Series	Valve Circuit Diagram
Counter Balance Valve	VSA A1A	30	17.2 (175)	—	H/S	
	VSCA 7A	30	17.2 (175)	—	H/S	
	V2CA 3A	15	20.6 (210)	—	2000	
	V2BA 1B	30	20.6 (210)	—	2000	
	V2MA 6A	60	20.6 (210)	—	2000	
Counter Balance Valve with Shuttle Valve	VSCA 4A+AC0578A -□□□	30	17.2 (175)	—	S	
	V2FA 5D- P2LF□□□	30	20.6 (210)	—	2000	
	V2PA 6A- P2LF□□□	60	20.6 (210)	—	2000	
Brake Valve	V2A□□□ A1□□□C	30	20.6 (210)	6.9–20.6 (70–210)	2000	
	V2L□□□ A6□□□B	60	20.6 (210)	6.9–20.6 (70–210)	2000	
Brake Valve with Anti-Cavitation Check Valve	VSE□□□ A3□□□B	15	17.2 (175)	6.9–13.7 (70–140)	H/S	
Super Shockless Brake Valve	VNS□□□ A1□□□A	30	20.6 (210)	6.9–20.6 (70–210)	2000	
	V4S□□□ A1□□□A	30	20.6 (210)	6.9–20.6 (70–210)	2000	

Eaton Industries (Japan) Ltd.
Head office & Tokyo sales office
Unizo Nogizaka Building,
8-11-37 Akasaka, Minato-ku,
Tokyo 107-0052
Japan
Tel: (+81 3) 5786 2560
Fax: (+81 3) 5786 2561

Eaton Industries (Japan) Ltd.
Osaka sales office
Mainichi Building INTECIO
12th Floor, 3-4-5 Umeda, Kita-ku,
Osaka 530-0001
Japan
Tel: (+81 6) 6136 6105
Fax: (+81 6) 6136 6107

Eaton Industries (Japan) Ltd.
Fukuoka sales office
Dai 6 Green Building,
2-12-19 Hakata Ekimae, Hakata-ku,
Fukuoka 812-0001
Japan
Tel: (+81 92) 475 5364
Fax: (+81 92) 412 2002

Eaton Industries (Japan) Ltd.
Kyoto Plant
Ooi-cho, Kameoka-shi,
Kyoto 621-0017
Japan
Tel: (+81 771) 22 9600
Fax: (+81 771) 29 2021

Eaton
Hydraulics Group Asia Pacific
Eaton Building
4th Floor, No.7 Lane280 Linhong Rd.
Changning District
Shanghai 200335
China
Tel: (+86 21) 5200 0099
Fax: (+86 21) 2230 7240